



THE BIOTECHNOLOGY
EDUCATION COMPANY®

**Includes EDVOTEK's All-NEW
DNA Standard Marker**

- Better separation
- Easier band measurements
- No unused bands

**NEW DNA Standard ladder sizes:
6751, 3652, 2827, 1568, 1118, 825, 630**



Revised
and
Updated

Edvo-Kit #225

DNA Fingerprinting Using Restriction Enzymes

Experiment Objective:

The objective of this simulated forensic analysis is to develop an understanding of the use of restriction enzymes as applied to RFLP-based DNA fingerprinting.

See page 3 for storage instructions.

Edvo-Kit #
225

Table of Contents

	Page
Experiment Components	3
Experiment Requirements	4
Background Information	5
Experiment Procedures	
Experiment Overview and General Instructions	11
Module I: Restriction Enzyme Digestion	13
Module II: Agarose Gel Electrophoresis	15
Module III: Staining Agarose Gels	17
Study Questions	19
Instructor's Guidelines	20
Module I: Pre-Lab Preparations	21
Module II: Pre-Lab Preparations	23
Module III: Pre-Lab Preparations	24
Experiment Results and Analysis	25
Study Questions and Answers	26
Appendices	27
A EDVOTEK® Troubleshooting Guide	28
B Bulk Preparation of Agarose Gels	29

Safety Data Sheets can be found on our website: www.edvotek.com/safety-data-sheets



Experiment Components

Component	Storage	Check (✓)
(Samples A and B are ready for electrophoresis)		
A Crime scene DNA sample, pre-cut with Restriction Enzyme 1	-20° C Freezer	<input type="checkbox"/>
B Crime scene DNA sample, pre-cut with Restriction Enzyme 2	-20° C Freezer	<input type="checkbox"/>
C Suspect #1 DNA sample	-20° C Freezer	<input type="checkbox"/>
D Suspect #2 DNA sample	-20° C Freezer	<input type="checkbox"/>
E DNA Standard Marker	-20° C Freezer	<input type="checkbox"/>
F Enzyme Reaction Buffer	-20° C Freezer	<input type="checkbox"/>
G Dryzymes™ Restriction Enzyme 1 (<i>EcoRI</i>)	-20° C Freezer	<input type="checkbox"/>
H Dryzymes™ Restriction Enzyme 2 (<i>HindIII</i>)	-20° C Freezer	<input type="checkbox"/>
I Reconstitution buffer	-20° C Freezer	<input type="checkbox"/>
J Enzyme Grade water	-20° C Freezer	<input type="checkbox"/>

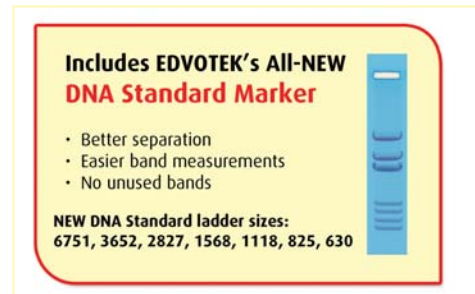

Experiment # 225
is designed for 6
groups.

Store the following components at room temperature.

- 10x Gel Loading Solution
- Practice Gel Loading Solution
- UltraSpec-Agarose™ powder
- 50x Concentrated Electrophoresis Buffer
- FlashBlue™ DNA Stain
- InstaStain™ Blue Cards
- 1 ml Pipets
- Microtipped Transfer Pipets
- Microcentrifuge Tubes with attached caps

All experiment components are intended for educational research only. They are not to be used for diagnostic or drug purposes, nor administered to or consumed by humans or animals.

EDVOTEK, InstaStain, and The Biotechnology Education Company are registered trademarks of EDVOTEK, Inc. Dryzymes, FlashBlue, and Ultra-Spec Agarose are trademarks of EDVOTEK, Inc.

1.800.EDVOTEK • Fax 202.370.1501 • info@edvotek.com • www.edvotek.com

Duplication of any part of this document is permitted for non-profit educational purposes only. Copyright © 2016 EDVOTEK, Inc., all rights reserved. 225.160913



Requirements *(not included with this kit)*

- Horizontal gel electrophoresis apparatus
- D.C. power supply
- Automatic micropipets with tips
- Water bath (37°C or 45°C)
- Balance
- Hot plate, Bunsen burner or microwave oven
- DNA visualization system (white light)
- Small plastic trays or large weigh boats (for gel destaining)
- Safety goggles and disposable laboratory gloves
- Pipet pumps
- 20 ml and 250 ml beakers or flasks
- Hot gloves
- Marking pens
- Distilled or deionized water
- Ice and ice buckets



Background Information

RESTRICTION ENZYMES

One of the most significant discoveries of molecular biology is a class of enzymes known as restriction endonucleases. These endonucleases (also known as restriction enzymes) are produced by many species of bacteria to protect themselves from invading viral DNA. Restriction enzymes act like molecular scissors, cutting double-stranded DNA at specific sequences. The utility of restriction enzymes has made molecular cloning, DNA mapping, sequencing and various genome-wide studies possible, launching the era of biotechnology.

Restriction Enzyme	Genus	Species	Strain	Recognition Site
<i>Ava I</i>	<i>Anabaena</i>	<i>variabilis</i>	<i>n/a</i>	C [^] YCGUG
<i>Bgl I</i>	<i>Bacillus</i>	<i>globigii</i>	<i>n/a</i>	GCCNNNN [^] NGGC
<i>EcoRI</i>	<i>Escherichia</i>	<i>coli</i>	<i>RY 13</i>	G [^] AATTC
<i>HaeIII</i>	<i>Haemophilus</i>	<i>aegyptius</i>	<i>n/a</i>	GG [^] CC
<i>HindIII</i>	<i>Haemophilus</i>	<i>influenzae</i>	<i>R_d</i>	A [^] AGCTT
<i>Sac I</i>	<i>Streptomyces</i>	<i>achromogenes</i>	<i>n/a</i>	GAGCT [^] C

Table 1: Common Restriction Enzymes with Recognition Sites

Since they were first discovered in the 1970s, over 3,000 restriction enzymes have been identified, each one given a unique acronym describing the organism from which it was first isolated. The first letter of the acronym is the first letter of the genus, the next two letters are the first two letters of the species name of the organism, and additional letters and numerals indicate specific strains and order of discovery. For example, *EcoRI* was the first restriction enzyme isolated from the RY13 strain of the bacterium *Escherchia coli*. (More examples are shown in Table 1.)

Many restriction enzymes require Mg²⁺ for activity and recognize palindromic stretches of DNA, generally 4-8 base pairs in length. The probability that a given enzyme will cut, or “digest”, a piece of DNA is directly proportional to the length of its recognition site. Statistically, an enzyme will average one cut for every 4ⁿ base pairs, where n is the length of the recognition site. For instance, an enzyme that recognizes a four base pairs long sequence (e.g., *HaeIII*) will cut DNA once every 256 (or 4⁴) base pairs, while an enzyme that recognizes a six base pairs long site (e.g., *EcoRI*) will cut once every 4096 (or 4⁶) base pairs. Therefore, the longer a DNA molecule is, the greater the probability is that it contains one or more restriction sites. For example, if *EcoRI* is used to digest human chromosomal DNA containing 3 billion base pairs and a plasmid containing 5,000 base pairs, it will cut the chromosomal DNA over 700,000 times (3 billion base pairs, cut every 4096 base pairs), but may only cut the plasmid once (5,000 base pairs, cut every 4096 base pairs).

Digestion by a restriction enzyme generates DNA fragments with one of two types of DNA ends--“sticky” or “blunt”. To illustrate this, first consider the recognition site and cleavage pattern of *EcoRI*.

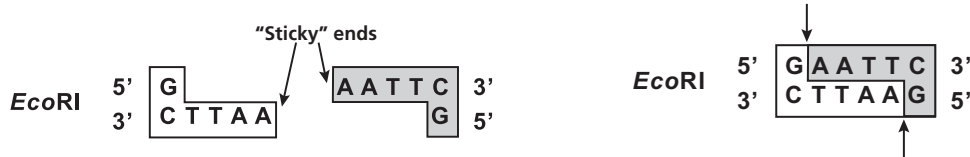

EcoRI cleaves between the G and neighboring A, as indicated by the arrows in the left side of the figure. It is important to note that the positions of the cleavage are staggered, so the resulting fragments project short overhangs of single-stranded DNA with complementary sequences. Such overhangs are referred to as “sticky” ends because the single-strands can interact with—or stick to—other overhangs with a complementary sequence (Figure 1). Digestion of the same piece of DNA using different enzymes can produce sticky ends of different lengths and strand orientation (5' vs. 3').

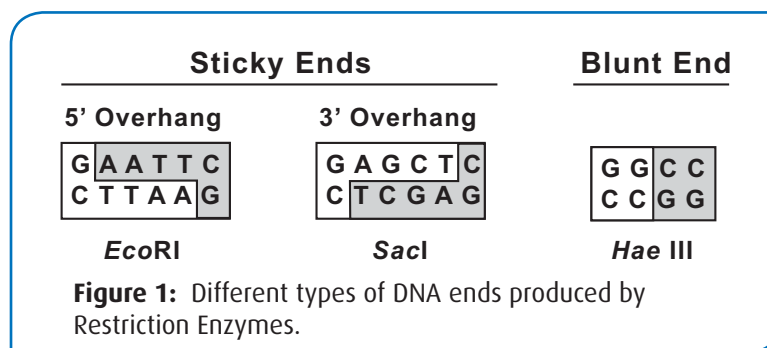

In contrast to *EcoRI*, *HaeIII* cuts both DNA strands at the same position, which generates fragments without an overhang. These so-called “blunt” ends can be joined with any other blunt end without regard for complementarity.

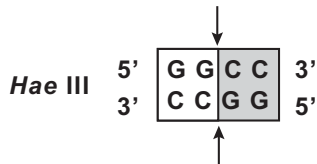

Some restriction enzymes, such as *AvaI*, recognize “degenerate” sites, which contain one or more variable positions.

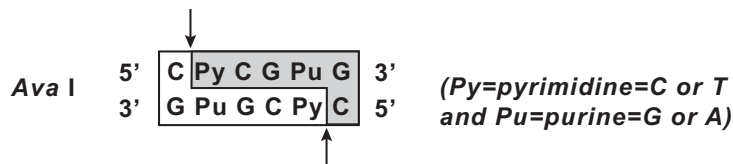

Consequently, there are four possible sites that *AvaI* will recognize and cut: CCCGGG, CCCGAG, CTCGGG and CTCGAG.

There are even enzymes like *Bgl*I that recognize “hyphenated” sites, which are palindromic sequences separated by a number of completely variable bases.

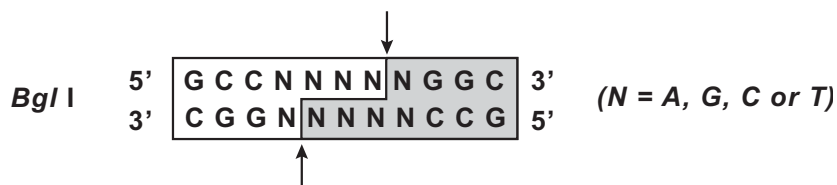

The six G-C base pairs that *Bgl*I specifically recognizes must be separated by five base pairs of DNA; otherwise the enzyme cannot properly interact with the DNA to cleave its backbone. Because these five base pairs are not required to make up a specific sequence, *Bgl*I can recognize and cleave up to 625 possible sequences!

Depending on the distances between recognition sites, digestion of DNA by a restriction enzyme will produce DNA fragments of varying lengths. In order to analyze such a mixture of DNA fragments, scientists use a technique called agarose gel electrophoresis.

AGAROSE GEL ELECTROPHORESIS

Agarose gel electrophoresis separates DNA fragments according to size (see figure). First, DNA molecules are added into depressions (or “wells”) within a gel (Figure 2A), and then an electrical current is passed through the gel. Because the sugar-phosphate backbone of DNA has a strong negative charge, the current drives the restriction fragments through the gel towards the positive electrode (Figure 2B).

At first glance, an agarose gel appears to be a solid at room temperature, but on the molecular level, the gel contains small channels through which the DNA can pass. Small DNA fragments move through these holes easily, but large DNA fragments have a more difficult time squeezing through the tunnels. Because molecules with dissimilar sizes travel at different speeds, they become separated and form discrete “bands” within the gel. After the current is stopped, the bands can be visualized using a stain that sticks to DNA. (Figure 2C)

While electrophoresis is a powerful separation technique, it is not without its technical limitations. Most significantly, if two different fragments share a similar size, they will migrate together through the gel and may appear as a single band. In addition, if digestion results in a broad distribution of DNA sizes, the fragments may stain as a smear. Lastly, DNA with a streamlined secondary structure (such as supercoiled DNA) can pass through the gel more quickly than similarly sized linear DNA, which prevents an accurate comparison of size.

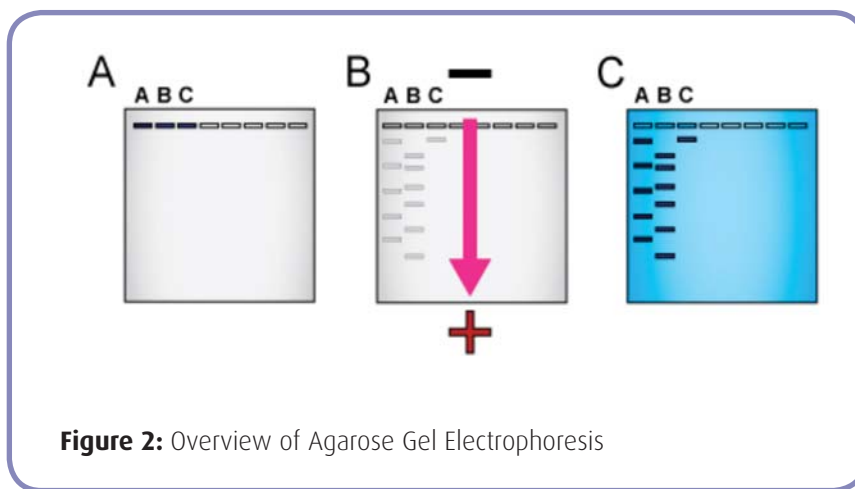

SOUTHERN BLOT ANALYSIS

RFLP analysis of genomic DNA is facilitated by Southern blot analysis. After electrophoresis, DNA fragments in the gel are denatured by soaking in an alkali solution. This causes double-stranded fragments to be converted into single-stranded form (no longer base-paired in a double helix). A replica of the electrophoretic pattern of DNA fragments in the gel is made by transferring (blotting) them to a sheet of nitrocellulose or nylon membrane (Figure 3). This is done by placing the membrane on the gel after electrophoresis and transferring DNA fragments to the membrane by capillary action or electrotransfer. DNA, which is not visible, becomes permanently adsorbed to the membrane, that can then be manipulated easier than gels.

Analysis of the blotted DNA is done by hybridization with a labeled oligonucleotide DNA probe. The probe is a DNA fragment that contains base sequences that are complementary to the variable arrays of tandemly repeated sequences found in the human chromosomes. Probes can be labeled with reporter molecules that are used for detection.

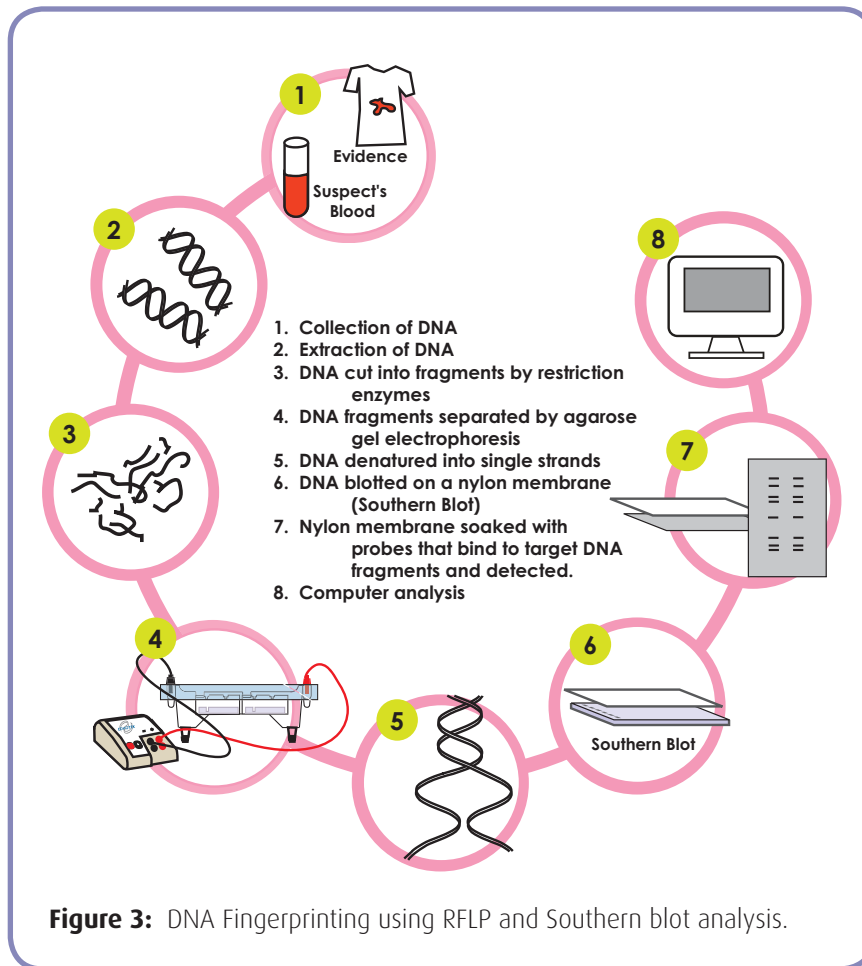

A solution containing the single-stranded probe is incubated with the membrane containing the blotted, single-stranded (denatured) DNA fragments. Under the proper conditions, the probe will only base pair (hybridize) to those fragments containing the complementary sequences. The membrane is then washed to remove excess probe. Only DNA fragments that are hybridized to the probe will reveal their positions on the membrane. If the probes are isotopically labeled, the hybridized fragments will appear as discrete bands (fingerprint) on the film and are in the same relative positions as they were in the agarose gel after electrophoresis. Only specific DNA fragments of the hundreds of thousands of fragments present, will hybridize with the probe because of the selective nature of the hybridization process.

Figure 3: DNA Fingerprinting using RFLP and Southern blot analysis.

In forensic analysis, DNA samples can be extracted and purified from specimens of skin, blood stains, semen, or hair roots collected at the crime scene. RFLP analyses performed on these samples is then compared to those performed on samples obtained from the suspect. If RFLP patterns match, it is beyond reasonable doubt that the suspect (or biological material from the suspect, such as blood) was at the crime scene. In forensic DNA fingerprinting, different sets of probes hybridized to different types of repetitious sequences are used in DNA profile analysis in order to satisfy certain statistical criteria for positive identification.

DNA FINGERPRINTING USING POLYMERASE CHAIN REACTION (PCR)

RFLP-based DNA fingerprinting analysis has been overtaken by the Polymerase Chain Reaction (PCR) because of two important advantages. The first is the sensitivity of PCR, which allows for DNA fingerprinting identification using much smaller amounts of DNA since PCR amplifies DNA. A second advantage is the speed of PCR analysis, which allows critical questions to be answered more quickly as compared to Southern Blot analysis.

PCR amplification requires the use of a thermostable DNA polymerase, such as *Taq* polymerase. Purified from a bacterium known as *Thermus aquaticus* that inhabits hot springs, *Taq* polymerase is commonly used in PCR because it remains stable at near-boiling temperatures. Also included in the PCR reaction are the four deoxynucleotides (dATP, dCTP, dGTP, and dTTP) and two synthetic oligonucleotides, typically 15-30 base pairs in length, known as "primers". These components, together with the DNA to be amplified, are incubated in an appropriate buffer that contains Mg^{2+} . The primers are designed to correspond to the start and end of the DNA to be amplified, known as the "target".

The PCR reaction mixture (which contains the DNA polymerase, buffer, deoxynucleotides, primers, and template) is subjected to sequential heating/cooling cycles at three different temperatures (Figure 5).

- In the first step, the template is heated to near boiling ($92^{\circ} - 96^{\circ}C.$) to denature or "melt" the DNA. This step, known as "denaturation" disrupts the hydrogen bonds between the two complementary DNA strands and causes their separation.
- In the second PCR step, the mixture is cooled to a temperature that is typically in the range of $45^{\circ} - 65^{\circ}C.$ In this step, known as "annealing", the primers, present in great excess to the template, bind to the separated DNA strands.
- In the third PCR step, known as "extension", the temperature is raised to an intermediate value, usually $72^{\circ}C.$ At this temperature the *Taq* polymerase is maximally active and adds nucleotides to the primers to complete the synthesis of the new complementary strands.

DNA fingerprinting analysis has become increasingly significant in court cases involving murder, rape, physical battery, and other types of crimes. Jurors are often asked to determine the validity of DNA evidence, resulting in both acquittals and convictions of suspected criminals. To ensure greater accuracy, scientists have incorporated standardization procedures in DNA analysis. DNA Standard Markers are used to determine the exact size of individual DNA fragments in a DNA fingerprint. It is generally accepted that DNA fingerprints are identical only in the case of identical twins.

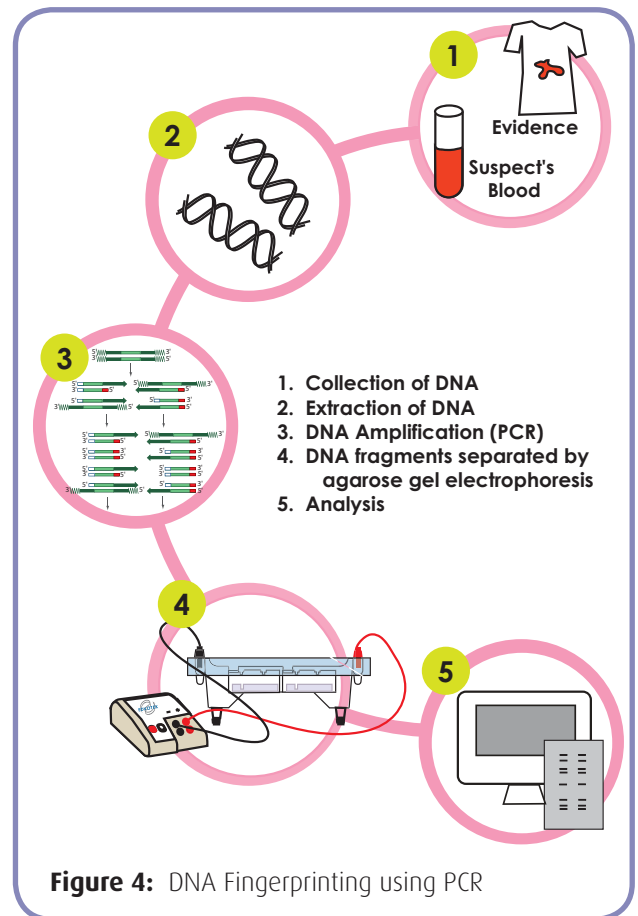

Figure 4: DNA Fingerprinting using PCR

In this experiment, emphasis is placed on concepts related to RFLP analysis. The experiment activities will focus on the identification of DNA by analyzing restriction fragmentation patterns separated by agarose gel electrophoresis.

THIS EXPERIMENT DOES NOT CONTAIN HUMAN DNA.

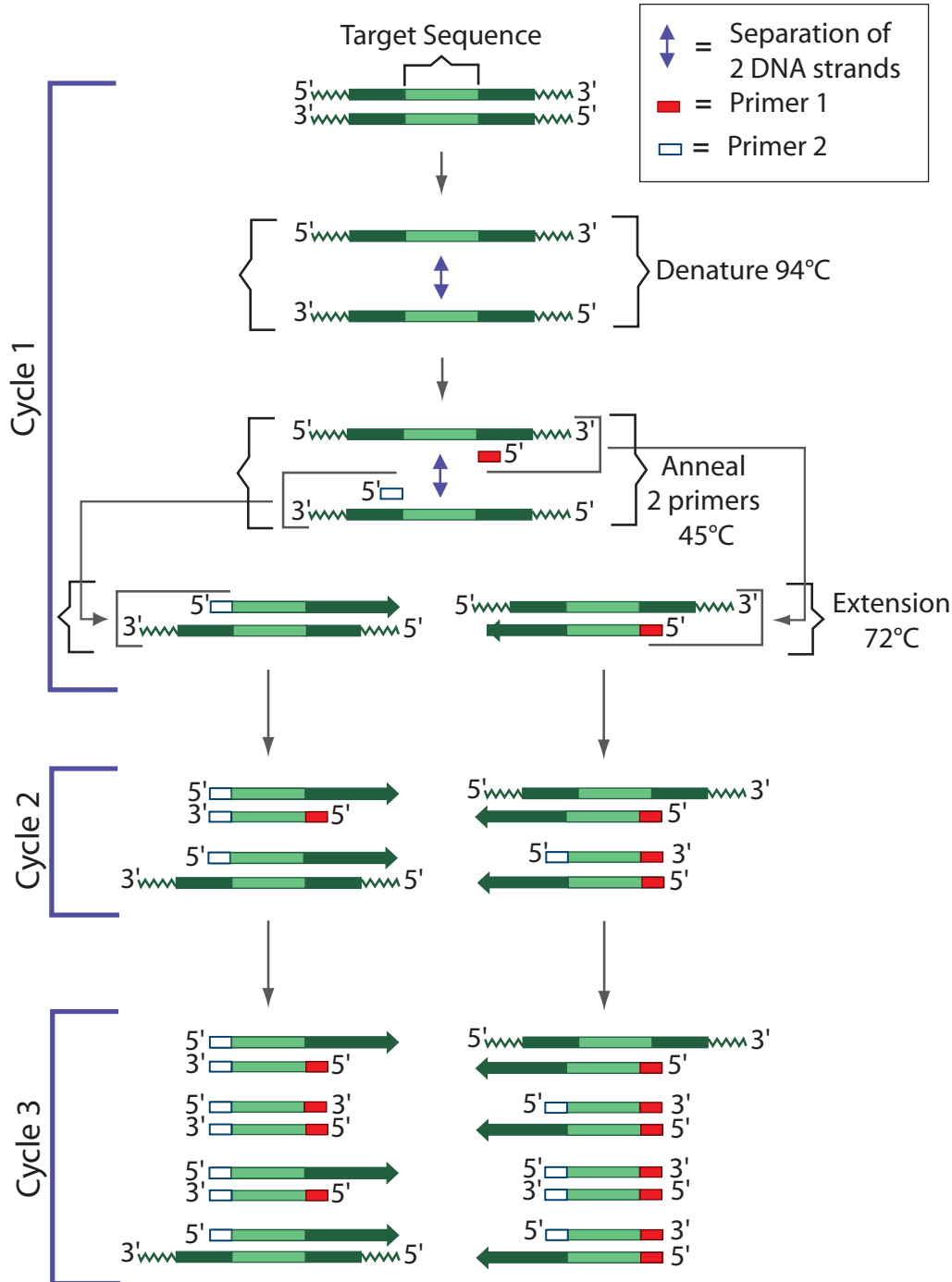

Figure 5: The Polymerase Chain Reaction

Experiment Overview

EXPERIMENT OBJECTIVE:

The objective of this simulated forensic analysis is to develop an understanding of the use of restriction enzymes as applied to RFLP-based DNA fingerprinting.

LABORATORY SAFETY

1. Gloves and goggles should be worn routinely as good laboratory practice.
2. Exercise extreme caution when working with equipment that is used in conjunction with the heating and/or melting of reagents.
3. DO NOT MOUTH PIPET REAGENTS - USE PIPET PUMPS.
4. Exercise caution when using any electrical equipment in the laboratory.
5. Always wash hands thoroughly with soap and water after handling reagents or biological materials in the laboratory.



LABORATORY NOTEBOOKS:

Scientists document everything that happens during an experiment, including experimental conditions, thoughts and observations while conducting the experiment, and, of course, any data collected. Today, you'll be documenting your experiment in a laboratory notebook or on a separate worksheet.

Before starting the Experiment:

- Carefully read the introduction and the protocol. Use this information to form a hypothesis for this experiment.
- Predict the results of your experiment.

During the Experiment:

- Record your observations.

After the Experiment:

- Interpret the results – does your data support or contradict your hypothesis?
- If you repeated this experiment, what would you change? Revise your hypothesis to reflect this change.

Crime Scene Investigation - Restriction Enzyme Digestion

In this experiment, the DNA from two suspects are each digested with two restriction enzymes in separate reactions and compared to crime scene samples after agarose gel electrophoresis. This flow chart outlines the procedure used for the restriction enzyme digestion of DNA obtained from Suspect 1. The DNA from Suspect 2 is digested in the same manner, using reaction tubes 3 and 4 (not shown).

MODULE I OVERVIEW

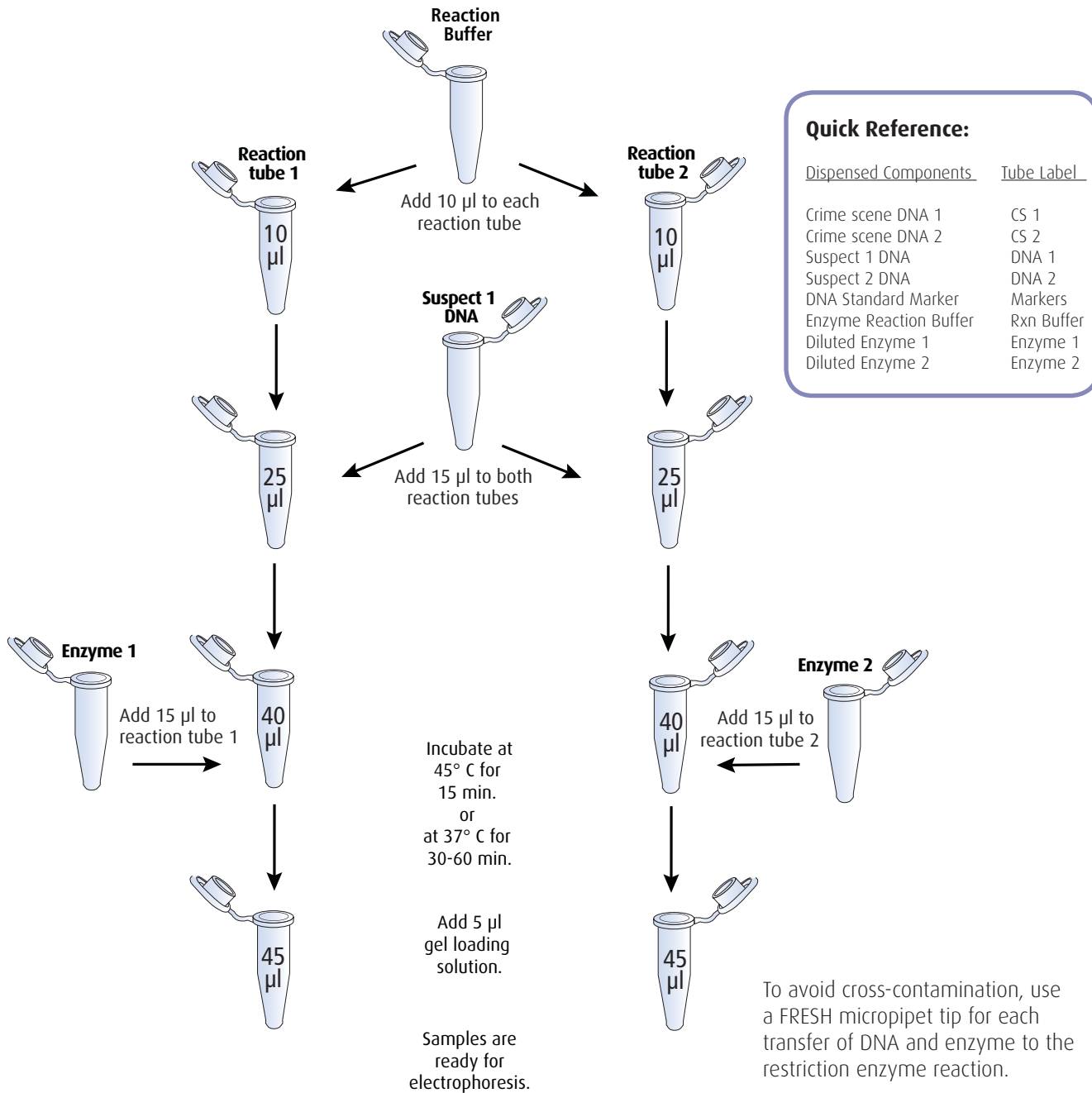

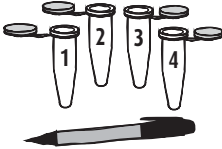

Module I: Crime Scene Investigation - Restriction Enzyme Digestion

1. Label tubes 

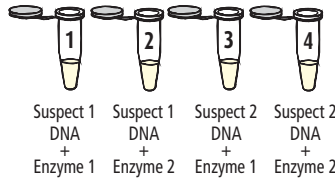
2. Add 10 μ l Enzyme Rxn Buffer 

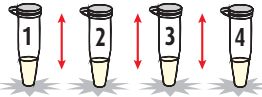
3. Add 15 μ l each DNA & Enzyme: 
 Suspect 1 DNA + Enzyme 1 Suspect 1 DNA + Enzyme 2 Suspect 2 DNA + Enzyme 1 Suspect 2 DNA + Enzyme 2

4. Cap and Tap tubes 

5.  **37°C**
30-60 min.

6. Add 5 μ l 10x Gel Loading Solution. 

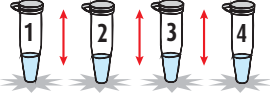
7. Cap and Tap tubes 

- LABEL** microcentrifuge tubes 1 through 4 for the four restriction enzyme digestion reactions. Put your initials or group number on the tubes.
- Use an automatic micropipet to **ADD** 10 μ l of Enzyme Reaction Buffer (Rxn Buffer) to each of four reaction tubes.
- ADD** 15 μ l of each DNA and enzyme to the reaction tubes as summarized in Table 2. Use a **FRESH** micropipet tip for each transfer of DNA and enzyme.
- CAP** the reaction tubes and **TAP** gently on the lab bench to mix and collect contents at the bottom of the tubes.
- INCUBATE** reaction tubes in a 37°C waterbath for 30 - 60 minutes. (Alternatively, tubes can be incubated in a 45°C waterbath for 15 minutes).

Table 2: Summary of Restriction Enzyme Digestion Reactions

Tube	Reaction Tube	Reaction Buffer	DNA 1 (μ l)	DNA 2 (μ l)	Enzyme 1 (μ l)	Enzyme 2 (μ l)	Final Volume (μ l)
SUSPECT 1	1	10	15	---	15	---	40
	2	10	15	---	---	15	40
SUSPECT 2	3	10	---	15	15	---	40
	4	10	---	15	---	15	40

IMPORTANT:

To prevent contamination, be sure to use a fresh pipet tip before going into the enzyme, DNA, and buffer stocks. Keep the enzymes on ice when not in use.

After the incubation is completed:

- ADD** 5 μ l of 10x gel loading solution to each of four reaction tubes to stop the reactions.
- CAP** tubes and **TAP** gently on the lab bench to mix.
- PROCEED** to Module II: Agarose Gel Electrophoresis.



OPTIONAL STOPPING POINT:

The restriction digest samples can be stored at -20°C for electrophoresis at a later time.

MODULE II OVERVIEW

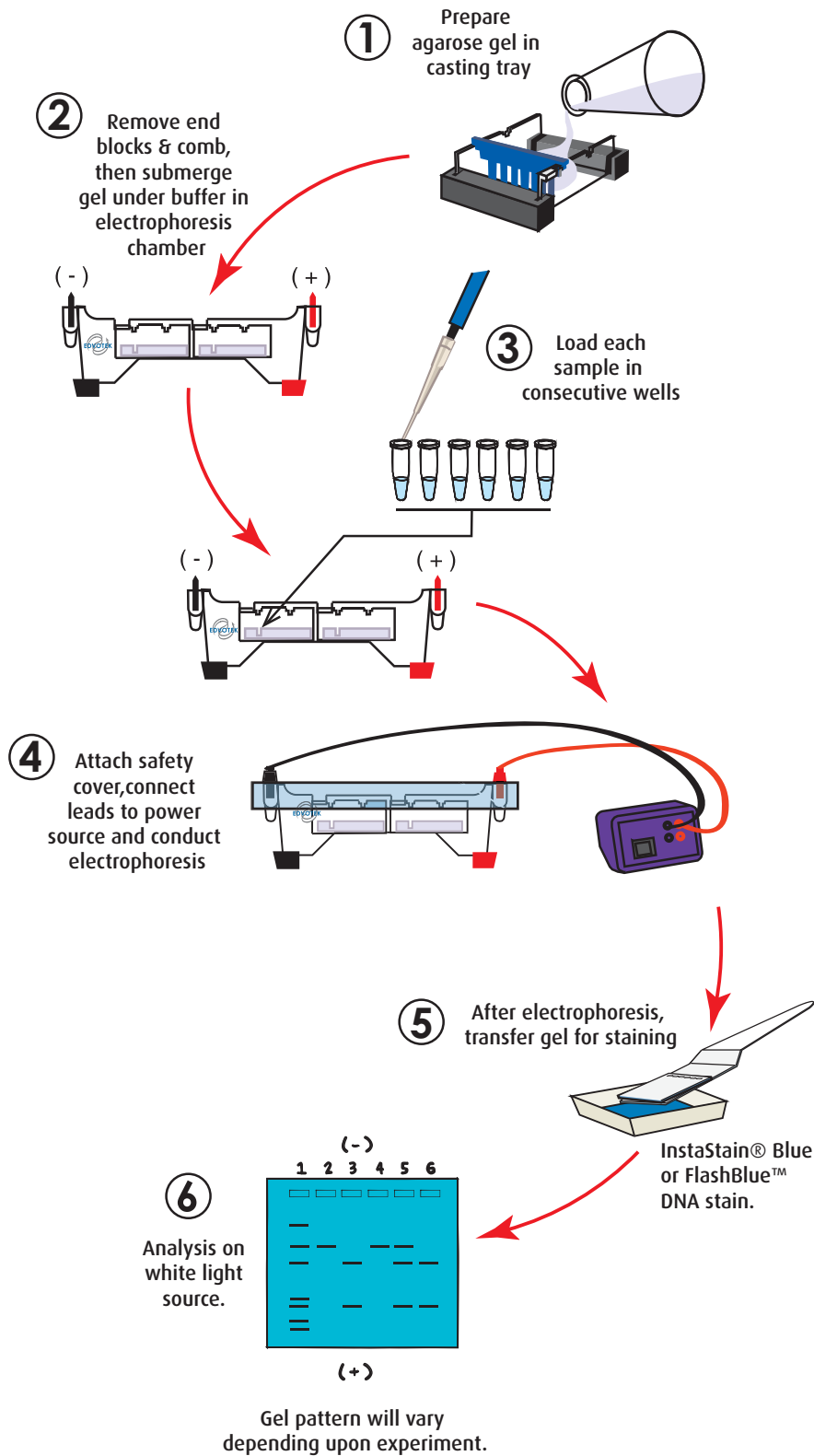

Module II: Agarose Gel Electrophoresis

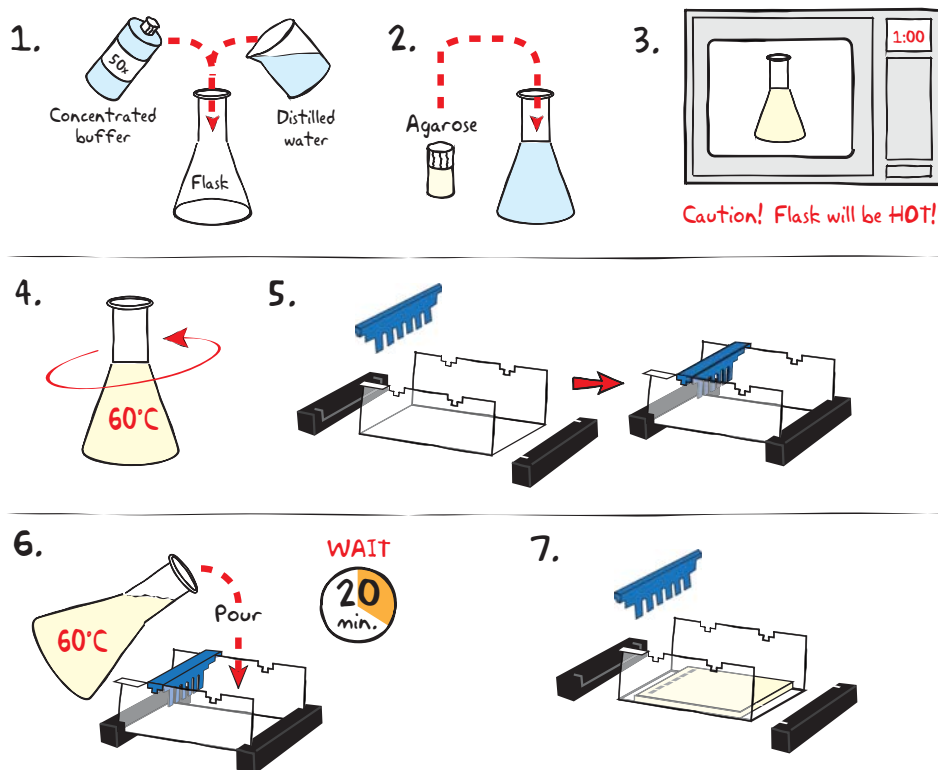

IMPORTANT:

Each student group requires 7-8 wells to analyze their samples by electrophoresis. We recommend the following:

- One 7 x 7 cm gel with an 8 well comb
- Two 7 x 7 cm gels with 6 well combs
- One 7 x 14 cm gel with 6 well combs placed in the first and third notches

If you are unfamiliar with agarose gel prep and electrophoresis, detailed instructions and helpful resources are available at www.edvotek.com

CASTING THE AGAROSE GEL

1. **DILUTE** concentrated 50X Electrophoresis buffer with distilled water (refer to Table A for correct volumes depending on the size of your gel casting tray).
2. **MIX** agarose powder with buffer solution in a 250 ml flask (refer to Table A).
3. **DISSOLVE** agarose powder by boiling the solution. **MICROWAVE** the solution on high for 1 minute. Carefully **REMOVE** the flask from the microwave and **MIX** by swirling the flask. Continue to **HEAT** the solution in 15-second bursts until the agarose is completely dissolved (the solution should be clear like water).
4. **COOL** agarose to 60° C with careful swirling to promote even dissipation of heat.
5. While agarose is cooling, **SEAL** the ends of the gel-casting tray with the rubber end caps. **PLACE** the well template (comb) in the appropriate notch.
6. **POUR** the cooled agarose solution into the prepared gel-casting tray. The gel should thoroughly solidify within 20 minutes. The gel will stiffen and become less transparent as it solidifies.
7. **REMOVE** end caps and comb. Take particular care when removing the comb to prevent damage to the wells.



Wear gloves and safety goggles

Table A				
Individual 0.8% UltraSpec-Agarose™ Gel				
Size of Gel Casting tray	Concentrated Buffer (50x)	Distilled Water	Amt of Agarose	TOTAL Volume
7 x 7 cm	0.6 ml	29.4 ml	0.23 g	30 ml
7 x 10 cm	1.0 ml	49.0 ml	0.39 g	50 ml
7 x 14 cm	1.2 ml	58.8 ml	0.46 g	60 ml

Module II: Agarose Gel Electrophoresis, continued

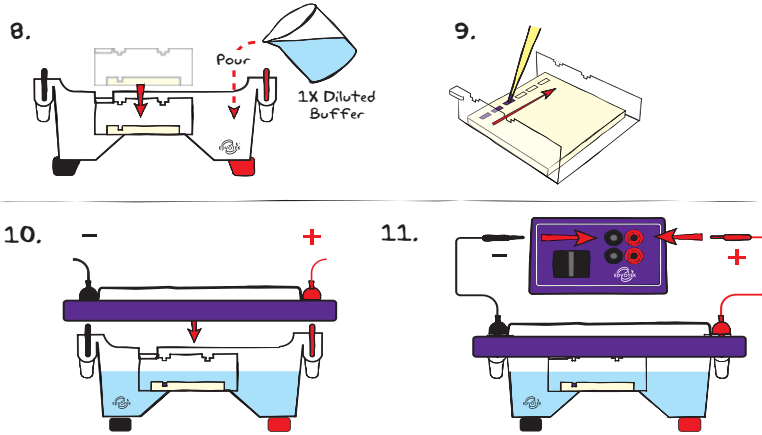

REMINDER:
Before loading the samples, make sure the gel is properly oriented in the apparatus chamber.

RUNNING THE GEL

8. **PLACE** the gel (still on the tray) into the electrophoresis chamber. **COVER** the gel with 1X Electrophoresis Buffer (See Table B for recommended volumes). The gel should be completely submerged.
9. **LOAD** 40 µl of the sample into the well in the order indicated by Table 3, at right. Your instructor will provide the pre-digested crime scene samples.
10. **PLACE** safety cover on the unit. **CHECK** that the gel is properly oriented. Remember, the DNA samples will migrate toward the positive (red) electrode.
11. **CONNECT** leads to the power source and **PERFORM** electrophoresis (See Table C for time and voltage guidelines). Allow the tracking dye to migrate at least 3.5 cm from the wells.
12. After electrophoresis is complete, **REMOVE** the gel and casting tray from the electrophoresis chamber and proceed to instructions for **STAINING** the agarose gel.

Table 3: Sample Loading

8-well Gels		
Lane	Tube	
1	Markers	Standard DNA Marker
2	CS 1	DNA from crime scene cut with Enzyme 1
3	CS 2	DNA from crime scene cut with Enzyme 2
4	1	DNA from suspect 1 cut with Enzyme 1
5	2	DNA from suspect 1 cut with Enzyme 2
6	3	DNA from suspect 2 cut with Enzyme 1
7	4	DNA from suspect 2 cut with Enzyme 2

6-well Gels		
First Row		
Lane	Tube	
1	Markers	Standard DNA Marker
2	CS 1	DNA from crime scene cut with Enzyme 1
3	CS 2	DNA from crime scene cut with Enzyme 2
4	1	DNA from suspect 1 cut with Enzyme 1
5	2	DNA from suspect 1 cut with Enzyme 2
Second Row		
Lane	Tube	
1	Markers	Standard DNA Marker
2	3	DNA from suspect 2 cut with Enzyme 1
3	4	DNA from suspect 2 cut with Enzyme 2

Table B 1x Electrophoresis Buffer (Chamber Buffer)

EDVOTEK Model #	Total Volume Required	Dilution	
		50x Conc. Buffer	+ Distilled Water
M6+ & M12 (new)	300 ml	6 ml	294 ml
M12 (classic)	400 ml	8 ml	392 ml
M36	1000 ml	20 ml	980 ml

Table C Time & Voltage Guidelines (0.8% Agarose Gel)

Volts	Electrophoresis Model		
	M6+	M12 (new)	M12 (classic) & M36
	Min. / Max.	Min. / Max.	Min. / Max.
150	15/20 min.	20/30 min.	25 / 35 min.
125	20/30 min.	30/35 min.	35 / 45 min.
75	35 / 45 min.	55/70 min.	60 / 90 min.

Module III-A: Staining Agarose Gels Using FlashBlue™

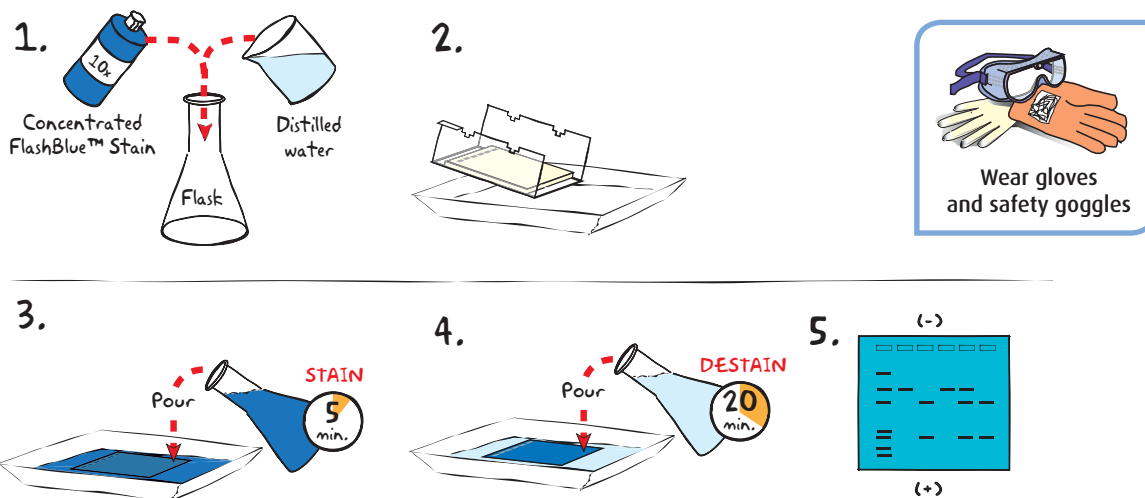

- DILUTE** 10 ml of 10x concentrated FlashBlue™ with 90 ml of water in a flask and **MIX** well.
- REMOVE** the agarose gel and casting tray from the electrophoresis chamber. **SLIDE** the gel off of the casting tray into a small, clean gel-staining tray.
- COVER** the gel with the 1x FlashBlue™ stain solution. **STAIN** the gel for 5 minutes. For best results, use an orbital shaker to gently agitate the gel while staining. **STAINING THE GEL FOR LONGER THAN 5 MINUTES WILL REQUIRE EXTRA DESTAINING TIME.**
- TRANSFER** the gel to a second small tray. **COVER** the gel with water. **DESTAIN** for at least 20 minutes with gentle shaking (longer periods will yield better results). Frequent changes of the water will accelerate destaining.
- Carefully **REMOVE** the gel from the destaining liquid. **VISUALIZE** results using a white light visualization system. DNA will appear as dark blue bands on a light blue background.

ALTERNATIVE PROTOCOL:

- DILUTE** one ml of concentrated FlashBlue™ stain with 149 ml dH₂O.
- COVER** the gel with diluted FlashBlue™ stain.
- SOAK** the gel in the staining liquid for at least three hours. For best results, stain gels overnight.
- Carefully **REMOVE** the gel from the staining liquid. **VISUALIZE** results using a white light visualization system. DNA will appear as dark blue bands on a light blue background.

Module III-B: Staining Agarose Gels Using InstaStain® Blue

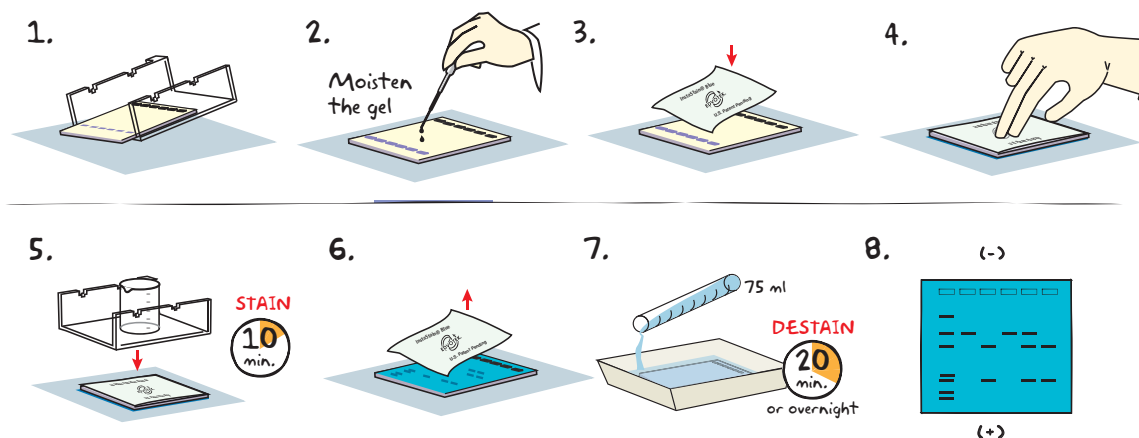

1. Carefully **REMOVE** the agarose gel and casting tray from the electrophoresis chamber. **SLIDE** the gel off of the casting tray on to a piece of plastic wrap on a flat surface.
2. **MOISTEN** the gel with a few drops of electrophoresis buffer.
3. Wearing gloves, **PLACE** the blue side of the InstaStain® Blue card on the gel.
4. With a gloved hand, **REMOVE** air bubbles between the card and the gel by firmly running your fingers over the entire surface. Otherwise, those regions will not stain.
5. **PLACE** the casting tray on top of the gel/card stack. **PLACE** a small weight (i.e. an empty glass beaker) on top of the casting tray. This ensures that the InstaStain® Blue card is in direct contact with the gel surface. **STAIN** the gel for 10 minutes.
6. **REMOVE** the InstaStain® Blue card. If the color of the gel appears very light, reapply the InstaStain® Blue card to the gel for an additional five minutes.
7. **TRANSFER** the gel to a small, clean gel-staining tray. **COVER** the gel with about 75 ml of distilled water and **DESTAIN** for at least 20 minutes. For best results, use an orbital shaker to gently agitate the gel while staining. To accelerate destaining, warm the distilled water to 37°C and change it frequently.
8. Carefully **REMOVE** the gel from the destaining liquid. **VISUALIZE** results using a white light visualization system. DNA will appear as dark blue bands on a light blue background.



NOTE:
DO NOT STAIN
GELS IN THE
ELECTROPHORESIS
APPARATUS.

ALTERNATIVE PROTOCOL:

1. Carefully **SLIDE** the agarose gel from its casting tray into a small, clean tray containing about 75 ml of distilled/deionized water or used electrophoresis buffer. The gel should be completely submerged.
2. Gently **FLOAT** the InstaStain® Blue card(s) on top of the liquid with the stain (blue side) facing toward the gel. Each InstaStain® Blue card will stain 49 cm² of gel (7 x 7 cm).
3. **COVER** the tray with plastic wrap to prevent evaporation. **SOAK** the gel in the staining liquid for at least 3 hours. The gel can remain in the liquid overnight if necessary.
4. Carefully **REMOVE** the gel from the staining liquid. **VISUALIZE** results using a white light visualization system. DNA will appear as dark blue bands on a light blue background.

Study Questions

1. Which suspect's DNA matches that found at the crime scene? Does this automatically mean that the suspect is guilty?
2. What possible experimental problems could occur to invalidate the results?
3. If only Restriction Enzyme 1 was used, would the interpretation be the same?

Instructor's Guide

ADVANCE PREPARATION:

Preparation For:	What to do:	When:	Time Required:
Module I: Restriction Enzyme Digestion	Prepare and aliquot reagents	One day to 30 minutes before performing the experiment.	20 min.
	Equilibrate water bath	One to two hours before the experiment.	10 min.
	Prepare and aliquot restriction enzymes	30 minutes before use.	30 min.
Module II: Agarose Gel Electrophoresis	Prepare diluted electrophoresis buffer	Any time before the class period.	10 min.
	Prepare molten agarose and pour gels	One day to 30 minutes before performing the experiment.	45 min.
Module III: Staining Agarose Gels	Prepare staining components	The class period or overnight before the class period.	10 min.

EDVO-TECH Service

1.800.EDVOTEK

Mon. - Fri. 8am-5:30pm EST



Please Have the Following Info:

- Product Number & Description
- Lot Number on Box
- Order/Purchase Order #
- Approx. Purchase Date

Fax: 202.370.1501 • info@edvotek.com • www.edvotek.com

www.edvotek.com

- Online Catalog
- Order Products
- Experiment Protocols
- Tech Support
- Resources!



Module I: Pre-Lab Preparations

NOTES FOR THE INSTRUCTOR:

This experiment simulates a forensic case in which DNA samples from a hypothetical crime scene and suspects are digested by six-base cutting enzymes (Eco RI and Hind III). The objective is to analyze suspect DNA fingerprint patterns and compare them with "crime scene" samples. Each DNA sample will be cleaved with two restriction enzymes in separate reactions, and pairs of fragmentation patterns will serve as the fingerprints. The DNA fragmentation patterns will be analyzed in the stained agarose gel, without the need for Southern blot analysis.

This experiment module contains biologicals and reagents for six groups. The experimental procedures consist of two major parts: 1) restriction enzyme digestion of DNA, which is followed by 2) agarose gel electrophoresis.

Each laboratory group receives two predigested, ready-for-electrophoresis "crime scene" samples and the DNA Standard Marker. Four additional DNA samples are generated by performing restriction enzyme digestion reactions on the DNAs of two suspects.

If you have six (6) electrophoresis units, one for each of the six lab groups, electrophoresis can be performed simultaneously by all six groups. Alternatively, some lab groups can store their samples at 4°C and perform the electrophoresis at different times.

PREPARATION OF BIOLOGICALS AND REAGENTS

1. Thaw all DNAs. Tap tubes on a table to get all the sample to the bottom of the tube.
2. Two tubes, components A and B, contain crime scene samples. These DNA samples have been cut with restriction enzymes and are ready for electrophoresis. Sample A represents "crime scene" DNA cut with Restriction Enzyme 1. Sample B represents "crime scene" DNA cut with Restriction Enzyme 2.
 - Label six tubes "CS 1" for the crime scene sample #1 (A).
 - Label six tubes "CS 2" for the crime scene sample #2 (B).
 - Dispense 45 µl of each crime scene sample in the appropriate tubes for each of the six lab groups.
3. Component E contains the DNA Standard Marker.
 - Label six tubes "Markers".
 - Dispense 85 µl of DNA Standard Marker to each tube for each of the six groups.
4. Component F is the Enzyme Reaction buffer.
 - Label six tubes "Rxn Buffer".
 - Dispense 45 µl of Enzyme Reaction buffer to each tube for each of the six groups.

PREPARATION OF SUSPECT DNA

5. Using an automatic micropipet, dispense the two Suspect DNAs (C, D) for each of the six lab groups.
 - For each of 6 groups, label two tubes: "DNA 1", & "DNA 2".
 - Dispense 35 µl of each Suspect DNA to the appropriate tube.

Quick Reference: Components for Restriction Enzyme Digestion

- A** Crime scene DNA sample, pre-cut with Restriction Enzyme 1
B Crime scene DNA sample, pre-cut with Restriction Enzyme 2

(Samples A and B are ready for electrophoresis)

- C** Suspect #1 DNA sample
D Suspect #2 DNA sample
E DNA Standard Marker
F Enzyme Reaction Buffer
G Restriction Enzyme 1
H Restriction Enzyme 2

Module I: Pre-Lab Preparations, continued

PREPARATION OF DRYZYME™ RESTRICTION ENZYMES

Prepare restriction digests within 30 minutes of reconstituting Dryzymes™.

1. Make sure that the solid material is at the bottom of the tubes. If not, centrifuge the tubes in a microcentrifuge at full speed for 20 seconds or tap the tube on the lab bench.
2. Add 120 µl Reconstitution Buffer (I) to the solid at the bottom of each tube containing Dryzymes™.
3. Allow the samples to hydrate for 1 minute.
4. Mix the samples vigorously by flicking the tubes with your finger or by vortexing for 30 seconds until the solid appears to be completely dissolved.
5. Add 120 µl Enzyme Grade Water (J) to each of the tubes of rehydrated Dryzymes™.
6. Mix or vortex the samples and then centrifuge for 20 seconds or tap the tube on the lab bench. After the rehydration, check that no undissolved particulate matter remains. If not completely dissolved, repeat mixing or vortexing.
7. Label six tubes "Enzyme 1" and six tubes "Enzyme 2".
8. Transfer 35 µl of diluted Restriction Enzyme 1 to each tube labeled "Enzyme 1". Cap the tubes and immediately put on ice.
9. Transfer 35 µl of diluted Restriction Enzyme 2 to each tube labeled "Enzyme 2". Cap the tubes and immediately put on ice.

GENERAL PREPARATIONS

1. Allow ample time to equilibrate a water bath at 45°C or 37°C on the day of the experiment.
2. Each student group can perform 4 restriction enzyme reactions. Each student group should receive the following materials:
 - Reagents and biologicals summarized in table, below.
 - Automatic micropipet and tips
 - 4 microtest tubes with attached caps
 - Marking pen

Summary of Biologicals and Reagents required for each of six groups

Component	Label 6 tubes each	Dispense for each tube*
A Crime scene DNA 1	CS 2	45 µl
B Crime scene DNA 2	CS 2	45 µl
C Suspect 1 DNA	DNA 1	35 µl
D Suspect 2 DNA	DNA 2	35 µl
E DNA Standard Marker	Markers	85 µl
F Reaction Buffer	Rxn Buffer	45 µl
I, J, G Diluted Enzyme 1	Enzyme 1	35 µl on ice
I, J, H Diluted Enzyme 2	Enzyme 2	35 µl on ice

NOTE:

Recommended dispensing volumes include a small amount of "excess" which is 5 µl more than the total volume required for the experiment.

Module II: Pre-Lab Preparations

AGAROSE GEL ELECTROPHORESIS

Each student group requires 7-8 wells to analyze their samples by electrophoresis. This can be accomplished in several different ways depending upon the equipment in your classroom. First, if 8-well combs are available (Cat. #683), each group would require one 7x7 cm gel. If 8-well combs are not available, each group would require either two 7X7 gels with 6-well combs, or one 7X14 gel with 6-well combs placed in the first and third notches. You can choose whether to prepare the gels in advance or have the students prepare their own. Allow approximately 30-40 minutes for this procedure.

Individual Gel Preparation:

Each student group can be responsible for casting their own individual gel prior to conducting the experiment. See Module I in the Student's Experimental Procedure. Students will need 50x Electrophoresis Buffer, distilled water and agarose powder.

Batch Gel Preparation:

To save time, a larger quantity of agarose solution can be prepared for sharing by the class. Electrophoresis buffer can also be prepared in bulk. See Appendix B.

Preparing Gels in Advance:

Gels may be prepared ahead and stored for later use. Solidified gels can be stored under buffer in the refrigerator for up to 2 weeks.

Do not freeze gels at -20° C as freezing will destroy the gels.

Gels that have been removed from their trays for storage should be "anchored" back to the tray with a few drops of molten agarose before being placed into the tray. This will prevent the gels from sliding around in the trays and the chambers.

NOTE:

Accurate pipetting is critical for maximizing successful experiment results. EDVOTEK Series 100 experiments are designed for students who have had previous experience with micropipetting techniques and agarose gel electrophoresis.

If students are unfamiliar with using micropipets, we recommend performing Cat. #S-44, Micropipetting Basics or Cat. #S-43, DNA DuraGel™ prior to conducting this advanced level experiment.

FOR MODULE II

Each Group Requires:

- 50x Electrophoresis Buffer
- 1 tube DNA Standard Marker
- Distilled Water
- UltraSpec-Agarose™
- Samples from Module I

Module III: Pre-Lab Preparations

MODULE III-A: STAINING AGAROSE GELS WITH FLASHBLUE™

FlashBlue™ stain is optimized to shorten the time required for both staining and de-staining steps. Agarose gels can be stained with diluted FlashBlue™ for 5 minutes and destained for only 20 minutes. For the best results, leave the gel in liquid overnight. This will allow the stained gel to “equilibrate” in the destaining solution, resulting in dark blue DNA bands contrasting against a uniformly light blue background. A white light box (Cat. #552) is recommended for visualizing gels stained with FlashBlue™.

- Stained gels may be stored in destaining liquid for several weeks with refrigeration, although the bands may fade with time. If this happens, re-stain the gel.
- Destained gels can be discarded in solid waste disposal. Destaining solutions can be disposed of down the drain.

MODULE III-B: STAINING AGAROSE GELS WITH INSTASTAIN® BLUE

The easiest and most convenient DNA stain available is InstaStain® Blue. InstaStain® Blue does not require the formulation, storage and disposal of large volumes of liquid stain. Each InstaStain® Blue card contains a small amount of blue DNA stain. When the card is placed in water, the DNA stain is released. This solution simultaneously stains and destains the gel, providing uniform gel staining with minimal liquid waste and mess.

You can use a White Light Visualization System (Cat. #552) to visualize gels stained with InstaStain® Blue.

PHOTODOCUMENTATION OF DNA (OPTIONAL)

Once gels are stained, you may wish to photograph your results. There are many different photodocumentation systems available, including digital systems that are interfaced directly with computers. Specific instructions will vary depending upon the type of photodocumentation system you are using.



FOR MODULE III-A Each Student Group should receive:

- 10 ml 10X concentrated FlashBlue OR 100 mL 1x diluted FlashBlue
- Small plastic tray or weight boat
- Distilled or deionized water

FOR MODULE III-B Each Student Group should receive:

- 1 InstaStain® card per 7 x 7 cm gel

Experiment Results and Analysis

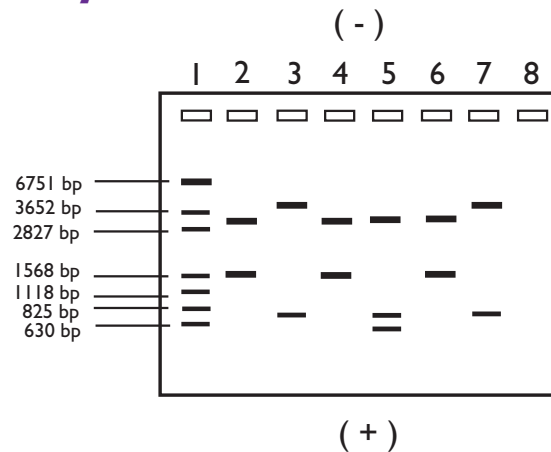
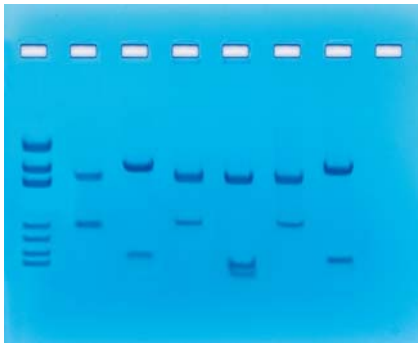

The restriction digest pattern from crime scene samples matches Suspect 2. This suggests Suspect 2 was at the crime scene.

The idealized schematic shows relative positions of DNA fragments. Actual results will yield broader bands of varying intensities. Smaller fragments will stain less efficiently and will appear as fainter bands. The idealized schematic shows the relative positions of the bands, but are not depicted to scale. A white light visualization system (Cat. #552) will aid with visualization.

Lane	Tube	Sample	Molecular Weight
1	Markers	DNA Standard Marker	6751, 3652, 2827, 1568, 1118, 825, 630
2	CS 1	DNA from crime scene cut with Enzyme 1	3000, 1280
3	CS 2	DNA from crime scene cut with Enzyme 2	3650, 630
4	1	DNA from Suspect 1 cut with Enzyme 1	3000, 1280
5	2	DNA from Suspect 1 cut with Enzyme 2	3000, 760, 650
6	3	DNA from Suspect 2 cut with Enzyme 1	3000, 1280
7	4	DNA from Suspect 2 cut with Enzyme 2	3650, 630

Includes EDVOTEK's All-NEW DNA Standard Marker

- Better separation
- Easier band measurements
- No unused bands

NEW DNA Standard ladder sizes:
6751, 3652, 2827, 1568, 1118, 825, 630



**Please refer to the kit
insert for the Answers to
Study Questions**

Appendices

- A EDVOTEK® Troubleshooting Guide
- B Bulk Preparation of Agarose Gels

Safety Data Sheets:

Now available for your convenient download on www.edvotek.com/safety-data-sheets

Appendix A

EDVOTEK® Troubleshooting Guides

PROBLEM:	CAUSE:	ANSWER:
The DNA did not digest	The restriction enzymes were not active.	Be sure that the restriction enzymes were diluted in the correct buffer.
		For optimal activity, prepare the enzymes within 30 minutes of use.
There are bands on my gels that can't be explained by the restriction digests.	Some bands may represent partially digested DNA.	The sample was not digested at the right temperature.
		The sample was not digested for the appropriate amount of time.
The ladder and student samples are not visible on the gel.	The gel was not prepared properly.	Ensure that the electrophoresis buffer was correctly diluted.
		Gels of higher concentration (>0.8%) require special attention when melting the agarose. Make sure that the solution is completely clear of "clumps" and glassy granules before pouring gels.
	The gel was not stained properly.	Repeat staining.
After staining the gel, the DNA bands are faint.	Malfunctioning electrophoresis unit or power source.	Contact the manufacturer of the electrophoresis unit or power source.
	The gel was not stained for a sufficient period of time.	Repeat staining protocol.
	DNA stained with FlashBlue or InstaStain Blue may fade over time.	Re-stain the gel with FlashBlue or InstaStain Blue.
After staining the gel, the ladder and control samples are visible on gel, but some student samples are not present.	Wrong volumes of DNA and enzyme added to restriction digest.	Destain gel for 5-10 minutes in distilled water.
		Practice using pipettes.
There is no separation between DNA bands, even though the tracking dye ran the appropriate distance.	The wrong percent gel was used for electrophoretic separation.	Be sure to prepare the correct percent agarose gel. For reference, the DNA samples should be analyzed using a 0.8% agarose gel.
DNA bands were not well resolved.	Tracking dye should migrate at least 3.5 cm from the wells to ensure adequate separation.	Be sure to run the gel at least 3.5 cm before staining and visualizing the DNA .

Appendix B

Bulk Preparation of Agarose Gels

To save time, the electrophoresis buffer and agarose gel solution can be prepared in larger quantities for sharing by the class. Unused diluted buffer can be used at a later time and solidified agarose gel solution can be remelted.

Bulk Electrophoresis Buffer

Quantity (bulk) preparation for 3 liters of 1x electrophoresis buffer is outlined in Table D.

Table D Bulk Preparation of Electrophoresis Buffer			
50x Conc. Buffer	+	Distilled Water	Total Volume Required
60 ml		2,940 ml	3000 ml (3 L)

Batch Agarose Gels (0.8%)

For quantity (batch) preparation of 0.8% agarose gels, see Table E.

- Use a 500 ml flask to prepare the diluted gel buffer.
- Pour 3.0 grams of UltraSpec-Agarose™ into the prepared buffer. Swirl to disperse clumps.
- With a marking pen, indicate the level of solution volume on the outside of the flask.
- Heat the agarose solution as outlined previously for individual gel preparation. The heating time will require adjustment due to the larger total volume of gel buffer solution.
- Cool the agarose solution to 60° C with swirling to promote even dissipation of heat. If evaporation has occurred, add distilled water to bring the solution up to the original volume as marked on the flask in step 3. 
- Dispense the required volume of cooled agarose solution for casting each gel. Measure 30 ml for a 7 x 7 cm tray, 50 ml for a 7 x 10 cm tray, and 60 ml for a 7 x 14 cm tray.
- Allow the gel to completely solidify. It will become firm and cool to the touch after approximately 20 minutes. Then proceed with preparing the gel for electrophoresis.

Note:

The UltraSpec-Agarose™ kit component is usually labeled with the amount it contains. Please read the label carefully. If the amount of agarose is not specified or if the bottle's plastic seal has been broken, weigh the agarose to ensure you are using the correct amount.

Table E Batch Prep of 0.8% UltraSpec-Agarose™					
Amt of Agarose (g)	+	Concentrated Buffer (50X) (ml)	+	Distilled Water (ml)	Total Volume (ml)
3.0		7.5		382.5	390