

Edvo-Kit #

**114**

Edvo-Kit #114

## DNA Paternity Testing Simulation

### Experiment Objective:

The objective of this experiment module is to introduce students to the use of DNA Fingerprinting in a hypothetical paternity determination.

See page 3 for storage instructions.

Version 114.210628

**EDVOTEK®**

# Table of Contents

	Page
Experiment Components	3
Experiment Requirements	3
Background Information	4
Experiment Procedures	
Experiment Overview	8
Module I: Agarose Gel Electrophoresis	10
Module II: Staining Agarose Gels Using FlashBlue™	12
Study Questions	13
Instructor's Guidelines	14
Pre-Lab Preparations	15
Experiment Results and Analysis	17
Study Questions and Answers	18
Appendices	19
A EDVOTEK® Troubleshooting Guide	20
B Bulk Preparation of Electrophoresis Buffer and Agarose Gels	21
C Using SYBR® Safe Stain (OPTIONAL)	22

Safety Data Sheets can be found on our website: [www.edvotek.com/safety-data-sheets](http://www.edvotek.com/safety-data-sheets)

## Technical Support

**1.800.EDVOTEK**

Mon. - Fri. 8 AM to 5:30 PM EST



**Please Have the Following Info:**

- Product Number & Description
- Lot Number on Box
- Order/Purchase Order #

**1.800.EDVOTEK • [info@edvotek.com](mailto:info@edvotek.com) • [www.edvotek.com](http://www.edvotek.com)**

## www.edvotek.com

- Online Catalog
- Order Products
- Experiment Protocols
- Tech Support
- Resources!



EDVOTEK and The Biotechnology Education Company are registered trademarks of EDVOTEK, Inc. Ready-to-Load, QuickStrip, FlashBlue, and UltraSpec-Agarose are trademarks of EDVOTEK, Inc. SYBR is a registered trademark of Thermo Fisher Scientific.



**1.800.EDVOTEK • Fax 202.370.1501 • [info@edvotek.com](mailto:info@edvotek.com) • [www.edvotek.com](http://www.edvotek.com)**

Duplication of any part of this document is permitted for non-profit educational purposes only. Copyright © 1989-2021 EDVOTEK, Inc., all rights reserved. Version 114.210628

## Experiment Components

### READY-TO-LOAD™ SAMPLES FOR ELECTROPHORESIS

#### Components (in QuickStrip™ format)

Store QuickStrip™ samples in the refrigerator upon receipt.

	Check (✓)
A DNA Standard Marker	<input type="checkbox"/>
B Mother DNA cut with Enzyme	<input type="checkbox"/>
C Child DNA cut with Enzyme	<input type="checkbox"/>
D Father 1 DNA cut with Enzyme	<input type="checkbox"/>
E Father 2 DNA cut with Enzyme	<input type="checkbox"/>

Experiment #114 is designed for 8 groups.

Store QuickStrip™ samples in the refrigerator immediately upon receipt. All other components can be stored at room temperature.

#### REAGENTS & SUPPLIES

Store the following at room temperature.

• UltraSpec-Agarose™	<input type="checkbox"/>
• Electrophoresis Buffer (50x)	<input type="checkbox"/>
• Practice Gel Loading Solution	<input type="checkbox"/>
• FlashBlue™ DNA Stain	<input type="checkbox"/>

## Requirements

- Horizontal gel electrophoresis apparatus
- D.C. power supply
- Automatic micropipettes with tips
- Balance
- Microwave, hot plate or burner
- Pipet pump
- 250 mL flasks or beakers
- Hot gloves
- Safety goggles and disposable laboratory gloves
- Small plastic trays or large weigh boats (for gel destaining)
- DNA visualization system (white light)
- Distilled or deionized water

All experiment components are intended for educational research only. They are not to be used for diagnostic or drug purposes, nor administered to or consumed by humans or animals.

## Background Information

DNA fingerprinting (also called DNA typing) allows for the identification of the source of DNA samples. The method has become very important to provide evidence in paternity and criminal cases. In contrast to the more conventional methodologies, such as blood typing, which can only exclude a suspect, DNA fingerprinting can provide positive identification with great accuracy.

Paternity determination based on DNA analysis (genetic DNA fingerprinting) has become an important procedure for matching children with biological fathers and mothers. Examples of recent court cases that have utilized this procedure have included rape, incest, immigration, citizenship of children to the United States and matching of children with parents who were mismatched at birth due to hospital errors. This type of testing is also used during unrest as in nations in civil war where children are often separated from parents and subsequently reunited.

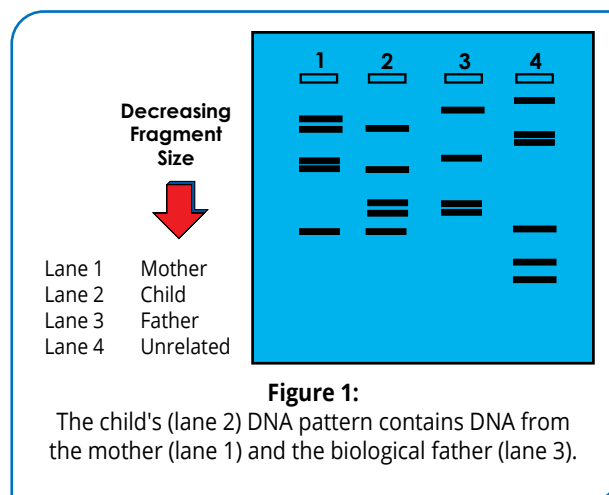

For paternity DNA fingerprinting, samples obtained from the mother, the child, and possible fathers are analyzed. A child's DNA is a composite of its parent DNAs. Therefore, comparison of DNA fragmentation patterns obtained from the mother and child will give a partial match. Bands in the child's DNA fingerprint that are not present in the mother's must be contributed by the father. Because of allelic differences, the DNA bands present in the child's fingerprint must be found in either the father's or mother's fingerprint.

Prior to the advent of the Polymerase Chain Reaction (PCR), DNA fingerprinting involved the electrophoretic analysis of DNA fragment sizes generated by restriction enzymes followed by Southern Blot Analysis. Restriction enzymes are endonucleases which catalyze the cleavage of the phosphate bonds within both strands of DNA. They require  $Mg^{+2}$  for activity and generate a 5 prime (5') phosphate and a 3 prime (3') hydroxyl group at the point of cleavage. The distinguishing feature of restriction enzymes is that they only cut at very specific sequences of bases called recognition sites. Restriction enzymes are produced by many different species of bacteria (including blue-green algae). Over 3,000 restriction enzymes have been discovered and catalogued.

Restriction enzymes are named according to the organism from which they are isolated. This is done by using the first letter of the genus followed by the first two letters of the species. Only certain strains or substrains of a particular species may be a producer of restriction enzymes. The type of strain or substrain sometimes follows the species designation in the name.

Finally, a Roman numeral is always used to designate one out of possibly several different restriction enzymes produced by the same organism or by different substrains of the same strain.

Restriction enzymes recognize specific double stranded sequences in DNA. Most recognition sites are 4 to 8 base pairs in length. Cleavage occurs within or near the site. The cleavage positions are indicated by arrows. With some exceptions, recognition sites are frequently symmetrical, i.e., both DNA strands in the site have the same base sequence when read 5' to 3'. Such sequences are called palindromes. It is these sites in DNA that are substrates for restriction enzymes. In DNA paternity and fingerprinting laboratories, the commonly used restriction enzymes are *Hae* III (GG'CC) and *Hinf* I (G'ANTC), which are 4-base and 5-base cutting enzymes respectively.

In this experiment, the DNAs from a hypothetical paternity case are cut by a restriction enzyme, which is a six-base cutting enzyme. Examples of six-base cutting enzymes include *Bam* HI and *Pst* I. The recognition sites for these restriction enzymes are:

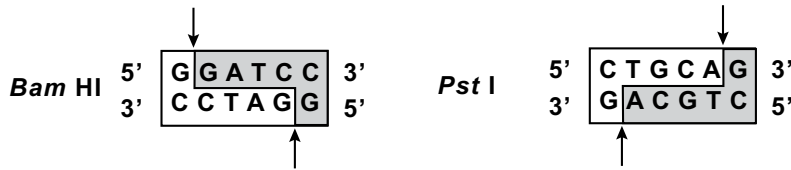

The size of the DNA fragments generated by restriction enzyme cleavage depends on the distance between the recognition sites. No two individuals have exactly the same pattern of restriction enzyme recognition sites. There are several reasons for this fact. A large number of alleles exist in the population. Alleles are alternate forms of a gene. It is estimated that about 25% of all human genes occur in multiple alleles which are called polymorphisms. Alleles result in alternative expressions of genetic traits which can be dominant or recessive and are inherited in a Mendelian pattern just as genes.

Restriction Enzyme	Organism
<i>Bam</i> HI	<i>Bacillus amyloliquefaciens</i>
<i>Hae</i> III	<i>Haemophilus aegyptius</i>
<i>Eco</i> RI	<i>Escherichia coli</i> , strain RY13
<i>Hin</i> I	<i>Haemophilus influenzae</i> Rf

**Figure 2:**  
Restriction enzyme names and bacterial sources.

Chromosomes occur in matching pairs, one of maternal and the other of paternal origin. The two copies of a gene (which can be alleles) at a given chromosomal locus, and which represent a composite of the parental genes, constitutes the unique genotype for an offspring. It follows that alleles have differences in their base sequences which consequently creates differences in the distribution and frequencies of restriction enzyme recognition sites. Other differences in base sequences between individuals can occur because of mutations and deletions. Such changes can also create or eliminate a recognition site.

The example in Figure 3 shows how a silent mutation can eliminate a recognition site but leave a protein product unchanged. Individual variations in the distances between recognition sites in chromosomal DNA are often caused by intervening repetitive base sequences. Repetitious sequences constitute a large fraction of the mammalian genome and have no known genetic function. These sequences can occur between genes or are adjacent to them. They are also found within introns. Ten to fifteen percent of mammalian DNA consists of sets of repeated, short sequences of bases that are tandemly arranged in arrays. The length of these arrays (the amount of repeated sets) varies between individuals at different chromosomal loci.

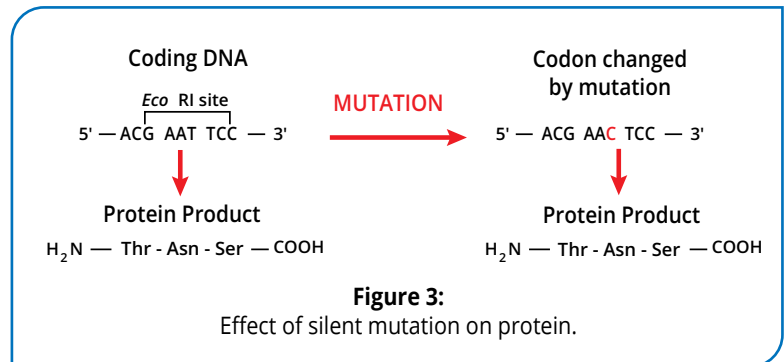

TGTTTA | TGTTTA | TGTTTA | .....variable number

When these arrays are flanked by recognition sites, the length of the repeat will determine the size of the restriction enzyme fragment generated. Variations in the length of these fragments between different individuals, in a population, are known as restriction fragment length polymorphisms, RFLPs. Several hundred RFLPs have been mapped on all 23 chromosomes. RFLPs are a manifestation of the unique molecular genetic profile, or "fingerprint", of an individual's DNA. As shown in Figure 4, there are several types of these short, repetitive sequences that have been cloned and purified. In Southern blot analysis, DNA probes are used to detect the length differences between these repetitive sequences. DNA probes are short fragments of single stranded DNA that are isotopically or non-isotopically labeled. DNA probes will complement and hybridize (attach) to single stranded DNA. Southern blot analysis requires electrophoresis, denaturation of the DNA fragments, transfer of DNA to a membrane, and exposure to probes to detect DNA Fingerprints.

There are two types of probes commonly used for genetic identification. The single-locus probes (SLPs) which detect a single segment of the repetitive DNA located at a specific site on a single chromosome. This will result in one or two DNA bands corresponding to one or both chromosome segments recognized. If the segments on the chromosome pairs are the same, then there will be one band. On the other hand, if they are different, it will appear as two bands. Several SLPs are available and are used less

frequently since more than one person can exhibit the same exact pattern for a specific SLP. Multiple-Locus probes (MLPs) detect multiple repetitive DNA segments located on many chromosomes yielding 20-30 bands. Because of the multi-band patterns, the chances of two people chosen at random having the same pattern is enormously remote. For example, it is calculated that two unrelated individuals having the identical DNA pattern detected by MLPs as an average is 1 in 30 billion. It should be kept in mind that the total human population on earth is between 5-6 billion.

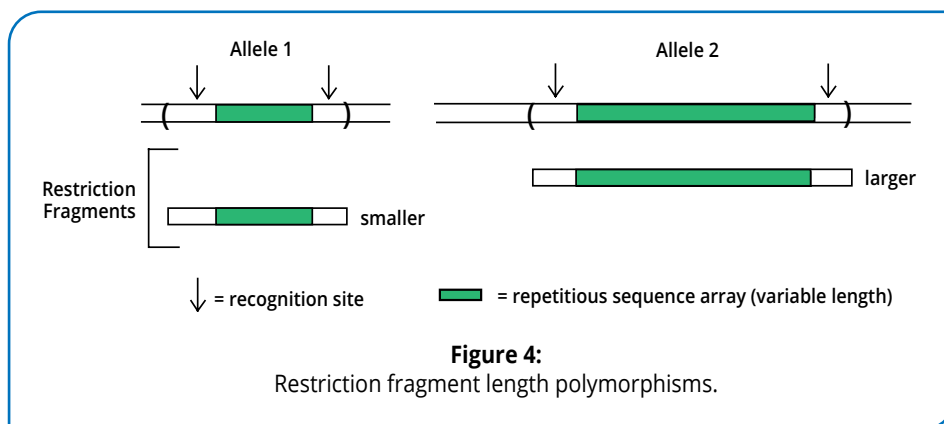

Currently, the polymerase chain reaction (PCR) is routinely used in forensics to analyze DNA (Figure 4). This technique requires about 500-fold less DNA than Southern blot RFLP analysis and is less time-consuming. PCR amplification (Figure 5) uses an enzyme known as Taq DNA polymerase. This enzyme, originally was purified from a bacterium that inhabits hot springs and is stable at very high (near boiling) temperatures. Also included in the PCR reaction mixture are two synthetic oligonucleotides known as “primers” and the extracted DNA. The region of DNA to be amplified is known as the “target”.

In the first step of the PCR reaction, the template complementary DNA strands are separated (denatured) from each other at 94°C, while the Taq polymerase remains stable. In the second step, known as annealing, the sample is cooled to 40°-65°C, to allow hybridization of the two primers, one to each of the two strands of the template DNA. In the third step, known as extension, the temperature is raised to 72°C and the Taq polymerase adds nucleotides to the primers to synthesize the new complementary strands. These three steps - denaturation, annealing, and extension - constitute one PCR “cycle”. This process is typically repeated for 20-40 cycles, amplifying the target sequence within DNA exponentially (Figure 5). PCR is performed in a thermal cycler, an instrument that is programmed to rapidly heat, cool and maintain samples at designated temperatures for varying amounts of time. The PCR products are separated by agarose gel electrophoresis and DNA fingerprints are analyzed.

In forensics and DNA paternity testing, PCR is used to amplify and examine highly variable (polymorphic) DNA regions. These are regions that vary in length from individual to individual and fall into two categories: 1) variable number of tandem repeats (VNTR) and 2) STR (short tandem repeats). A VNTR is a region that is variably composed of a 15-70 base pair sequence, typically repeated 5-100 times. An STR is similar to a VNTR except that the repeated unit is only 2-4 nucleotides in length. By examining several different VNTRs or STRs from the same individual, investigators obtain a unique DNA profile for that individual which is unlike that of any other person (except for identical twins).

In this simulation experiment, DNA was extracted from samples obtained from the mother, child and two possible fathers. The objective is to analyze and match the DNA fragment patterns after agarose gel electrophoresis and determine if Father 1 or Father 2 is the biological parent of the child.

THIS EXPERIMENT DOES NOT CONTAIN HUMAN DNA.

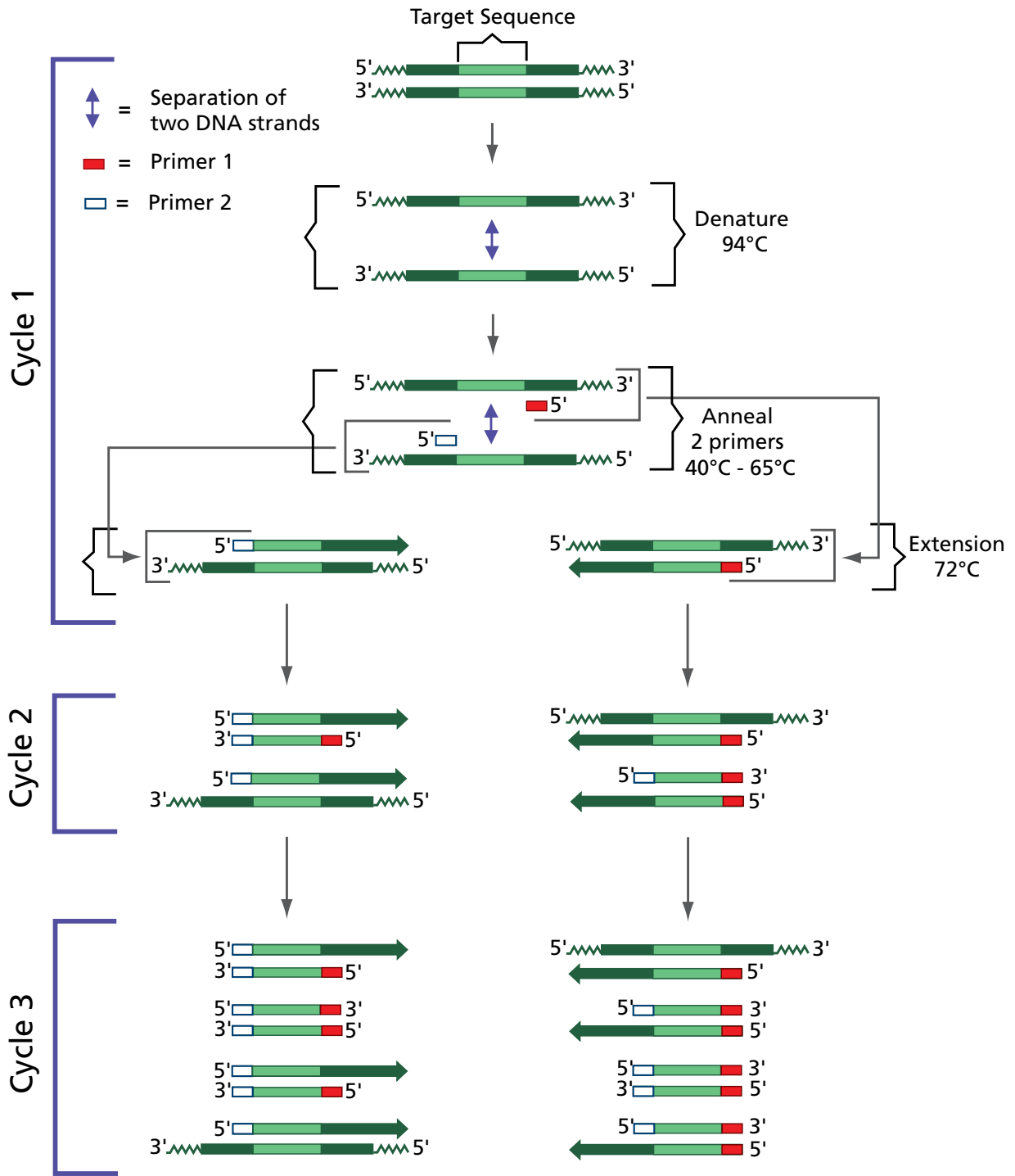

**Figure 5:**  
DNA Amplification by the Polymerase Chain Reaction

# Experiment Overview

## EXPERIMENT OBJECTIVE

The objective of this experiment module is to introduce students to the use of DNA Fingerprinting in a hypothetical paternity determination.

## LABORATORY SAFETY

1. Gloves and goggles should be worn routinely as good laboratory practice.
2. Exercise extreme caution when working with equipment that is used in conjunction with the heating and/or melting of reagents.
3. DO NOT MOUTH PIPET REAGENTS - USE PIPET PUMPS.
4. Exercise caution when using any electrical equipment in the laboratory.
5. Always wash hands thoroughly with soap and water after handling reagents or biological materials in the laboratory.



## LABORATORY NOTEBOOKS

Scientists document everything that happens during an experiment, including experimental conditions, thoughts and observations while conducting the experiment, and, of course, any data collected. Today, you'll be documenting your experiment in a laboratory notebook or on a separate worksheet.

### Before starting the Experiment:

- Carefully read the introduction and the protocol. Use this information to form a hypothesis for this experiment.
- Predict the results of your experiment.

### During the Experiment:

- Record your observations.

### After the Experiment:

- Interpret the results – does your data support or contradict your hypothesis?
- If you repeated this experiment, what would you change? Revise your hypothesis to reflect this change.



## Experiment Overview

### MODULE I: Agarose Gel Electrophoresis

*Time required: See Table C*

Quick Reference for EDVO-Kit #114			
Size of gel casting tray	Groups per gel	Placement of comb	Wells required per group
7 x 7 cm	1 group	1st set of notches	5
10 x 7 cm	1 group	1st set of notches	5
14 x 7 cm	2 groups	1st and 3rd sets of notches	5

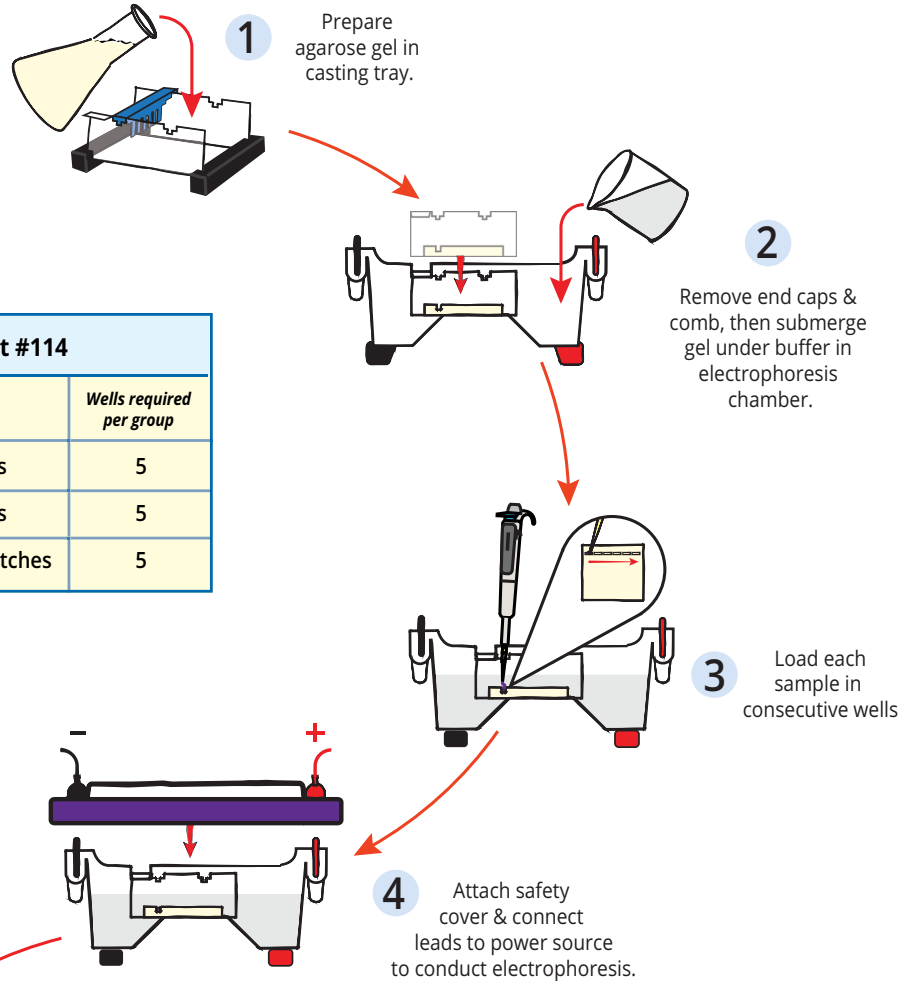

### MODULE II: Staining Agarose Gels Using FlashBlue™

*Time required: 30 min.*

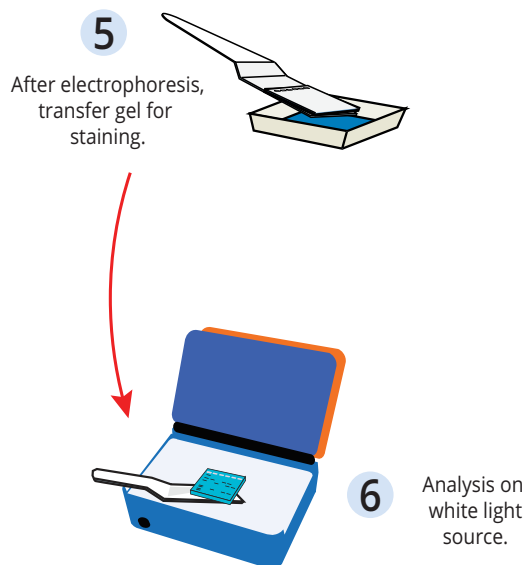

### Related EDVOTEK® Instructional Videos

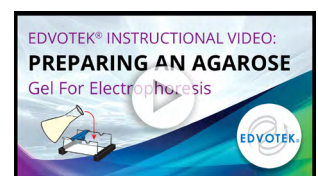
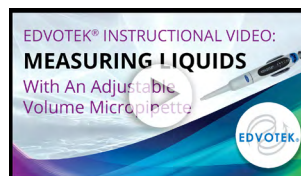

[www.youtube.com/edvotekinc](http://www.youtube.com/edvotekinc)

# Module I: Agarose Gel Electrophoresis

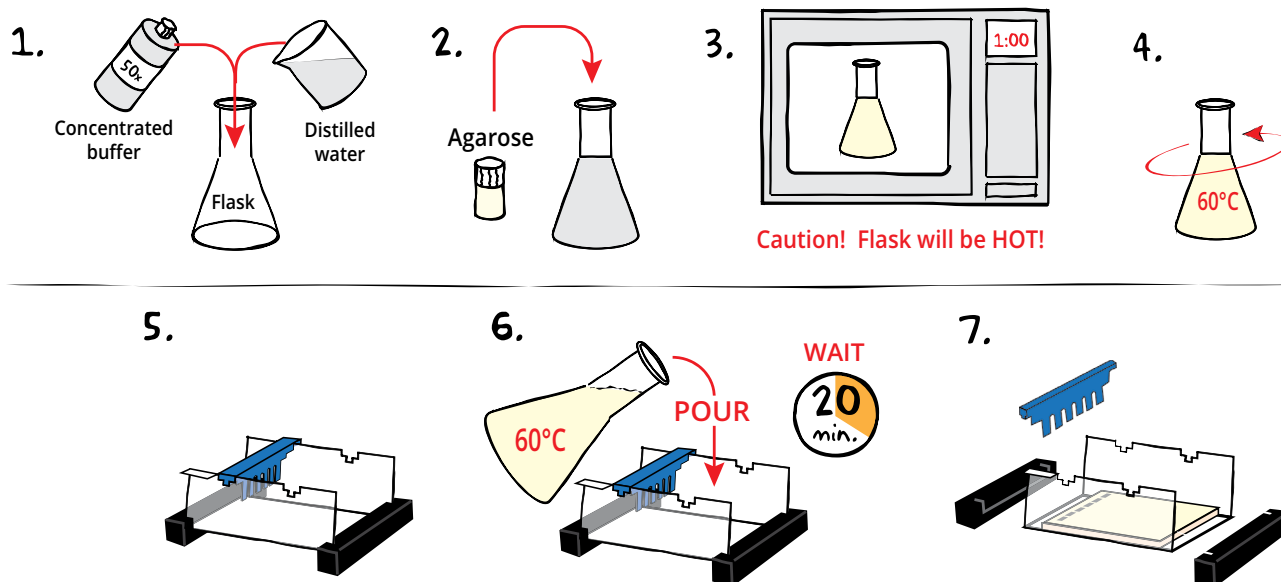

## CASTING THE AGAROSE GEL

- DILUTE** concentrated 50X Electrophoresis buffer with distilled water (refer to Table A for correct volumes depending on the size of your gel casting tray).
- MIX** agarose powder with buffer solution in a 250 mL flask (refer to Table A).
- DISSOLVE** agarose powder by boiling the solution. **MICROWAVE** the solution on high for 1 minute. Carefully **REMOVE** the flask from the microwave and **MIX** by swirling the flask. Continue to **HEAT** the solution in 15-second bursts until the agarose is completely dissolved (the solution should be clear like water).
- COOL** agarose to 60 °C with careful swirling to promote even dissipation of heat.
- While agarose is cooling, **SEAL** the ends of the gel-casting tray with the rubber end caps. **PLACE** the well template (comb) in the appropriate notch.
- POUR** the cooled agarose solution into the prepared gel-casting tray. The gel should thoroughly solidify within 20 minutes. The gel will stiffen and become less transparent as it solidifies.
- REMOVE** end caps and comb. Take particular care when removing the comb to prevent damage to the wells.



Wear gloves and safety goggles

### REMINDER:

This experiment requires 0.8% agarose gels cast with 6 wells.

Size of Gel Casting tray	Concentrated Buffer (50x)	+ Distilled Water	+ Amt of Agarose	= TOTAL Volume
7 x 7 cm	0.6 mL	29.4 mL	0.24 g	30 mL
10 x 7 cm*	0.9 mL	44.1 mL	0.36 g	45 mL
14 x 7 cm	1.2 mL	58.8 mL	0.48 g	60 mL

\*Recommended gel volume for the EDGE™ Integrated Electrophoresis System. (Cat. #500).

## Module I: Agarose Gel Electrophoresis

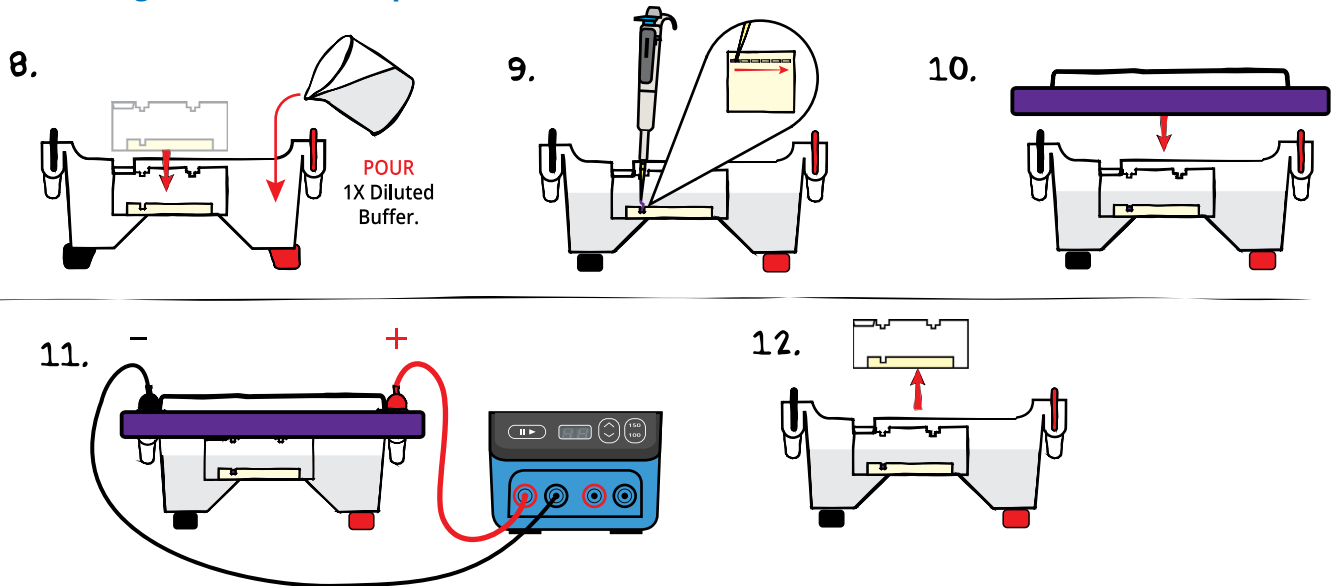

### RUNNING THE GEL

- PLACE** the gel (still on the tray\*) into the electrophoresis chamber. **COVER** the gel with 1X Electrophoresis Buffer (See Table B for recommended volumes). The gel should be completely submerged.
- PUNCTURE** the foil overlay of the QuickStrip™ with a pipet tip. **LOAD** the entire sample (35 µL) into the well in the order indicated by Table 1, at right.
- PLACE** safety cover on the unit. **CHECK** that the gel is properly oriented. Remember, the DNA samples will migrate toward the positive (red) electrode.
- CONNECT** leads to the power source and **PERFORM** electrophoresis (See Table C for time and voltage guidelines). Allow the tracking dye to migrate at least 3 cm from the wells.
- After electrophoresis is complete, **REMOVE** the gel and casting tray from the electrophoresis chamber.

**REMINDER:**  
Before loading the samples, make sure the gel is properly oriented in the apparatus chamber.

**TABLE 1: GEL LOADING**

Lane 1	Tube	DNA Standard Marker
2	Tube B	Mother DNA cut with Enzyme
3	Tube C	Child DNA cut with Enzyme
4	Tube D	Father 1 DNA cut with Enzyme
5	Tube E	Father 2 DNA cut with Enzyme

**Table B**  
**1x Electrophoresis Buffer (Chamber Buffer)**

EDVOTEK Model #	Total Volume Required	Dilution	
		50x Conc. Buffer	+ Distilled Water
EDGE™	150 mL	3 mL	147 mL
M12	400 mL	8 mL	392 mL
M36	1000 mL	20 mL	980 mL

**Table C**  
**Time and Voltage Guidelines (0.8% Agarose Gel)**

Volts	Electrophoresis Model	
	EDGE™	M12 & M36
	Min/Max (minutes)	Min/Max (minutes)
150	10/20	20/35
125	N/A	30/45
100	15/25	40/60

\*Gels that have previously been removed from their trays should be “anchored” back to the tray with a few drops of molten agarose before placing into the electrophoresis chamber. This will prevent the gels from sliding around in the trays and the chambers.

## Module II: Staining Agarose Gels Using FlashBlue™

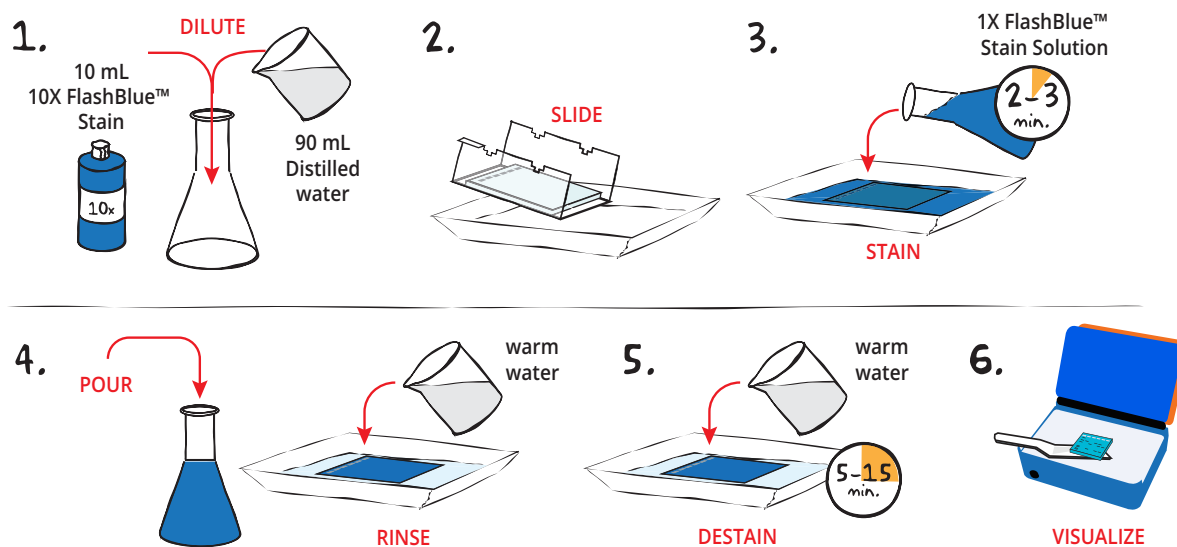

- DILUTE** 10 mL of 10X concentrated FlashBlue™ with 90 mL of distilled water in a flask. **MIX** well.
- REMOVE** the agarose gel and casting tray from the electrophoresis chamber. **SLIDE** the gel off the casting tray into a small, clean gel-staining tray.
- COVER** the gel with the 1X FlashBlue™ stain solution. **STAIN** the gel for 2-3 minutes. For best results, use an orbital shaker to gently agitate the gel while staining. **STAINING THE GEL FOR LONGER THAN 3 MINUTES WILL REQUIRE EXTRA DESTAINING TIME.**
- POUR** the 1X FlashBlue™ back into the flask (the stain can be reused). **COVER** the gel with warm water (40-45 °C). Gently **RINSE** the gel for 20-30 seconds. **POUR** off the water.
- COVER** the gel with clean, warm water (40-45 °C). **DESTAIN** for 5-15 minutes with gentle shaking (longer periods will yield better results). DNA bands will start to appear after 5 minutes of destaining. Changing the water frequently will accelerate destaining.
- Carefully **REMOVE** the gel from the destaining liquid. **VISUALIZE** results using a white light visualization system. DNA will appear as dark blue bands on a light blue background.



### ALTERNATIVE FLASHBLUE™ STAINING PROTOCOL:

- DILUTE** 1 mL of 10X FlashBlue™ stain with 149 mL distilled water.
- COVER** the gel with diluted FlashBlue™ stain.
- SOAK** the gel in the staining liquid for at least three hours. For best results, stain gels overnight.
- Carefully **REMOVE** the gel from the staining liquid. **VISUALIZE** results using a white light visualization system. DNA will appear as dark blue bands on a light blue background.

## Study Questions

---

1. Why do different individuals such as siblings have different restriction enzyme recognition sites?
2. What is the function of PCR primers used in DNA paternity analysis?
3. Why is there more than one single locus used in an actual paternity DNA test?
4. Why do we not use probes in this DNA paternity simulation and still obtain results?

# Instructor's Guide

## ADVANCE PREPARATION:

PREPARATION FOR:	WHAT TO DO:	WHEN?	TIME REQUIRED:
<b>Module I: Agarose Gel Electrophoresis</b>	Prepare QuickStrips™.	Up to one day before performing the experiment.	45 min.
	Prepare diluted electrophoresis buffer.		
	Prepare molten agarose and pour gels.		
<b>Module II: Staining Agarose Gels Using FlashBlue™</b>	Prepare staining components.	The class period or overnight after the class period.	10 min.

## Technical Support

**1.800.EDVOTEK**

Mon. - Fri. 8 AM to 5:30 PM EST



### Please Have the Following Info:

- Product Number & Description
- Lot Number on Box
- Order/Purchase Order #

1.800.EDVOTEK • [info@edvotek.com](mailto:info@edvotek.com) • [www.edvotek.com](http://www.edvotek.com)

**www.edvotek.com**

- Online Catalog
- Order Products
- Experiment Protocols
- Tech Support
- Resources!



## Pre-Lab Preparations: Module I

### AGAROSE GEL ELECTROPHORESIS

This experiment requires 0.8% agarose gels. Enough reagents are provided to cast either eight 7 x 7 cm gels, eight 10 x 7 cm gels, or four 14 x 7 cm gels. You can choose whether to prepare the gels in advance or have students prepare their own. Allow approximately 30 minutes for this procedure.

Quick Reference for EDVO-Kit #114			
Size of gel casting tray	Groups per gel	Placement of comb	Wells required per group
7 x 7 cm	1 group	1st set of notches	5
10 x 7 cm	1 group	1st set of notches	5
14 x 7 cm	2 groups	1st and 3rd sets of notches	5

#### Individual Gel Preparation:

Each student group can be responsible for casting their own individual gel prior to conducting the experiment. See Module I in the Student's Experimental Procedure. Students will need 50x concentrated buffer, distilled water and agarose powder.

#### Batch Gel Preparation:

To save time, a larger quantity of agarose solution can be prepared for sharing by the class. Electrophoresis buffer can also be prepared in bulk. See Appendix B.

#### Preparing Gels in Advance:

Gels may be prepared ahead and stored for later use. Solidified gels can be stored under buffer in the refrigerator for up to 2 weeks.

Do not freeze gels at -20 °C as freezing will destroy the gels.

Gels that have been removed from their trays for storage should be "anchored" back to the tray with a few drops of molten agarose before being placed into the tray. This will prevent the gels from sliding around in the trays and the chambers.

#### SAMPLES FORMAT: PREPARING THE QUICKSTRIPS™

QuickStrip™ tubes consist of a microtiter block covered with a protective foil overlay. Each well contains pre-aliquoted sample.

Using sharp scissors, carefully divide the block of tubes into individual strips by cutting between the rows (see diagram at right). Take care not to damage the foil overlay while separating the samples.

Each lab group will receive one set of tubes. Before loading the gel, remind students to tap the tubes to collect the sample at the bottom of the tube. Puncture the foil overlay of the QuickStrip™ with a pipet tip to aspirate the sample. **Do not remove the foil as samples can spill.**

**FOR MODULE I**  
**Each group will need:**

- 50x concentrated buffer
- Distilled Water
- UltraSpec-Agarose™
- QuickStrip™ Samples

**NOTE:**  
This kit is compatible with **SYBR® Safe Stain** (Cat #608, not included). Instructions for preparing gels and visualizing results can be found in Appendix C.

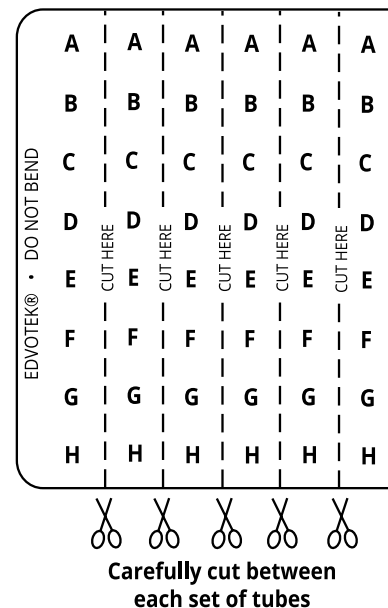

## Pre-Lab Preparations: Module II

### STAINING AGAROSE GELS USING FLASHBLUE™

FlashBlue™ stain is optimized to shorten the time required for both staining and destaining steps. Agarose gels can be stained with diluted FlashBlue™ for 5 minutes and destained for only 20 minutes. For the best results, leave the gel in liquid overnight. This will allow the stained gel to “equilibrate” in the destaining solution, resulting in dark blue DNA bands contrasting against a uniformly light blue background. A white light box ([Cat. #552](#)) is recommended for visualizing gels stained with FlashBlue™.

- Stained gels may be stored in destaining liquid for several weeks with refrigeration, although the bands may fade with time. If this happens, re-stain the gel.
- Destained gels can be discarded in solid waste disposal. Destaining solutions can be disposed of down the drain.

#### FOR MODULE II Each group will need:

- 10 mL 10X concentrated FlashBlue *OR* 100 mL 1x diluted FlashBlue
- Small plastic tray or weight boat
- Distilled or deionized water

### PHOTODOCUMENTATION OF DNA (OPTIONAL)

Once gels are stained, you may wish to photograph your results. There are many different photodocumentation systems available, including digital systems that are interfaced directly with computers. Specific instructions will vary depending upon the type of photodocumentation system you are using.

#### NOTE:

Accurate pipetting is critical for maximizing successful experiment results. EDVOTEK Series 100 experiments are designed for students who have had previous experience with micropipetting techniques and agarose gel electrophoresis.

If students are unfamiliar with using micropipettes, we recommended performing [Cat. #S-44, Micropipetting Basics](#) or [Cat. #S-43, DNA DuraGel™](#) prior to conducting this experiment.



## Experiment Results and Analysis

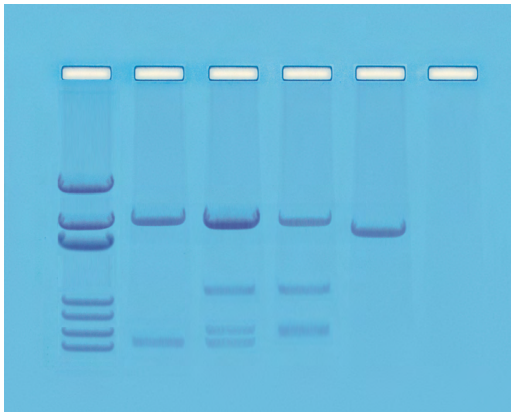

### Includes EDVOTEK's All-NEW DNA Standard Marker

- Better separation
- Easier band measurements
- No unused bands

**NEW DNA Standard ladder sizes:**  
6751, 3652, 2827, 1568, 1118, 825, 630



In the idealized schematic, the relative positions of DNA fragments are shown but are not depicted to scale.

Lane	Tube	Sample	Molecular Weights (in bp)
1	A	DNA Standard Markers	6751, 3652, 2827, 1568 1118, 825, 630
2	B	Mother DNA cut with Enzyme	3652, 630
3	C	Child DNA cut with Enzyme	3652, 1300, 700, 630
4	D	Father 1 DNA cut with Enzyme	3652, 1300, 700
5	E	Father 2 DNA cut with Enzyme	3000

Parentage (meaning maternity and paternity) can be determined from a child's DNA profile. By comparing the DNA profile of a mother and her child it is possible to identify DNA fragments in the child which are absent from the mother. Therefore, these polymorphisms have been inherited from the biological father. In this case, the two bands in the child's DNA profile that are not explained by the mother's profile are found in father #1.

**Please refer to the kit  
insert for the Answers to  
Study Questions**

# Appendices

- A EDVOTEK® Troubleshooting Guide
- B Bulk Preparation of Electrophoresis Buffer and Agarose Gels
- C Using SYBR® Safe Stain (OPTIONAL)

Safety Data Sheets can be found on our website: [www.edvotek.com/safety-data-sheets](http://www.edvotek.com/safety-data-sheets)

## Technical Support

**1.800.EDVOTEK**

Mon. - Fri. 8 AM to 5:30 PM EST



### Please Have the Following Info:

- Product Number & Description
- Lot Number on Box
- Order/Purchase Order #

1.800.EDVOTEK • [info@edvotek.com](mailto:info@edvotek.com) • [www.edvotek.com](http://www.edvotek.com)

**www.edvotek.com**

- Online Catalog
- Order Products
- Experiment Protocols
- Tech Support
- Resources!



## Appendix A

### EDVOTEK® Troubleshooting Guides

PROBLEM:	CAUSE:	ANSWER:
Bands are not visible on the gel.	The gel was not prepared properly.	Ensure that the electrophoresis buffer was correctly diluted.
	The gel was not stained properly.	Repeat staining protocol.
	Malfunctioning electrophoresis unit or power source.	Contact the manufacturer of the electrophoresis unit or power source.
After staining the gel, the DNA bands are faint.	The gel was not stained for a sufficient period of time.	Repeat staining protocol.
	The background of gel is too dark after staining with FlashBlue™.	Destain the gel for 5-10 minutes in distilled water.
DNA bands were not resolved.	Tracking dye should migrate at least 3 cm from the wells to ensure adequate separation.	Be sure to run the gel at least 3 cm before staining and visualizing the DNA (approximately 15-20 minutes at 150 V).
DNA bands fade when gels are kept at 4 °C.	DNA stained with FlashBlue™ may fade with time.	Re-stain the gel with FlashBlue™.
There is no separation between DNA bands, even though the tracking dye ran the appropriate distance.	The wrong percent gel was used for electrophoretic separation.	Be sure to prepare the correct percent agarose gel. For reference, the Ready-to-Load™ DNA samples should be analyzed using a 0.8% agarose gel.
There's not enough sample in my QuickStrip™.	The QuickStrip™ has dried out.	Add 40 µL water, gently pipet up and down to mix before loading.

Visit [www.edvotek.com](http://www.edvotek.com) for additional troubleshooting suggestions.

## Appendix B

### Bulk Preparation of Electrophoresis Buffer and Agarose Gels

To save time, the electrophoresis buffer and agarose gel solution can be prepared in larger quantities for sharing by the class. Unused diluted buffer can be used at a later time and solidified agarose gel solution can be remelted.

#### Bulk Electrophoresis Buffer

Quantity (bulk) preparation for 3 liters of 1x electrophoresis buffer is outlined in Table D.

Table D Bulk Preparation of Electrophoresis Buffer			
50x Conc. Buffer	+	Distilled Water	Total Volume Required
60 mL		2,940 mL	3000 mL (3 L)

#### Batch Agarose Gels (0.8%)

For quantity (batch) preparation of 0.8% agarose gels, see Table E.

1. Use a 500 mL flask to prepare the diluted gel buffer.
2. Pour 3.0 grams of UltraSpec-Agarose™ into the prepared buffer. Swirl to disperse clumps.
3. With a marking pen, indicate the level of solution volume on the outside of the flask.
4. Heat the agarose solution as outlined previously for individual gel preparation. The heating time will require adjustment due to the larger total volume of gel buffer solution.
5. Cool the agarose solution to 60 °C with swirling to promote even dissipation of heat. If evaporation has occurred, add distilled water to bring the solution up to the original volume as marked on the flask in step 3.
6. Dispense the required volume of cooled agarose solution for casting each gel. Measure 30 mL for a 7 x 7 cm tray, 45 mL for a 10 x 7 cm tray, and 60 mL for a 14 x 7 cm tray. **For this experiment, 7 x 7 cm gels are recommended.**
7. Allow the gel to completely solidify. It will become firm and cool to the touch after approximately 20 minutes. Solidified gels can be stored under buffer in the refrigerator for up to 2 weeks. Do not freeze gels.

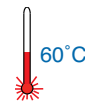

Table E Batch Prep of 0.8% UltraSpec-Agarose™					
Amt of Agarose	+	Concentrated Buffer (50X)	+	Distilled Water	Total Volume
3.0 g		7.5 mL		367.5 mL	375 mL

#### NOTE:

The UltraSpec-Agarose™ kit component is usually labeled with the amount it contains. Please read the label carefully. If the amount of agarose is not specified or if the bottle's plastic seal has been broken, weigh the agarose to ensure you are using the correct amount.

PROCEED to Loading and Running the Gel (page 11).

## Appendix C

### Using SYBR® Safe DNA Stain (OPTIONAL)

If desired, the DNA samples in this experiment can be visualized using [SYBR® Safe DNA stain \(Cat #608\)](#).

We recommend adding diluted SYBR® Safe stain to the liquid agarose gels while casting for easy, reproducible results. A blue light or UV transilluminator is needed for visualizing SYBR® gels. The TruBlu™ 2 ([Cat. #557](#)) is highly recommended.

#### PREPARING SYBR® SAFE STAIN

##### Instructors:

1. Prepare 1x Electrophoresis Buffer by combining 10 µL of 50X Concentrated Buffer with 490 µL of distilled water.
2. Add 20 µL of the SYBR® Safe to the tube of 1X buffer from Step 1 and mix by tapping the tube several times. The diluted SYBR® Safe Stain is now ready to be used during agarose gel preparation.

#### AGAROSE GEL PREPARATION

This experiment requires one 0.8% agarose gel for each student group. Instructors can choose whether to prepare the gels in advance (METHOD A) or have the students prepare their own (METHOD B). Allow approximately 30-40 minutes for this procedure.

##### Instructor Preparation (METHOD A):

For quantity (batch) preparation of agarose gels, see Table E.

1. Use a 500 mL flask to prepare the diluted gel buffer.
2. Pour 3.0 grams of UltraSpec-Agarose™ into the prepared buffer. Swirl to disperse clumps.
3. With a marking pen, indicate the level of solution volume on the outside of the flask.
4. Heat the agarose solution as outlined previously for individual gel preparation. The heating time will require adjustment due to the larger total volume of gel buffer solution.
5. Cool the agarose solution to 60 °C with swirling to promote even dissipation of heat. If evaporation has occurred, add distilled water to bring the solution up to the original volume as marked on the flask in step 3.
6. Add the entire tube of **diluted SYBR® Safe** stain to the cooled agarose and mix well.
7. Dispense the required volume of cooled agarose solution for casting each gel. Measure 30 mL for a 7 x 7 cm tray, 45 mL for a 10 x 7 cm tray, and 60 mL for a 14 x 7 cm tray. **For this experiment, 7 x 7 cm gels are recommended.**
8. Allow the gel to completely solidify. It will become firm and cool to the touch after approximately 20 minutes. Solidified gels can be stored in the refrigerator for up to 2 weeks. Place 1-2 mL of electrophoresis buffer in a sealable bag with the gels to prevent them from drying out. Excessive buffer will cause SYBR® Safe to diffuse out of the gels. Do not freeze gels.

PROCEED to Loading and Running the Gel (Steps 8-12 on page 11), followed by the VISUALIZATION procedures on page 24.

**NO ADDITIONAL STAINING IS NECESSARY.**

Table E					
Batch Prep of 0.8% UltraSpec-Agarose™					
Amt of Agarose	+	Concentrated Buffer (50X)	+	Distilled Water	Total Volume
3.0 g		7.5 mL		367.5 mL	375 mL

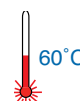

## Appendix C

### Using SYBR® Safe DNA Stain (OPTIONAL)

#### AGAROSE GEL PREPARATION, CONTINUED

##### Student Preparation (METHOD B):

For student preparation of agarose gels, see Table A.2.

1. **DILUTE** concentrated (50X) buffer with distilled water to create 1X buffer (see Table A.2).
2. **MIX** agarose powder with 1X buffer in a 250 mL flask (see Table A).
3. **DISSOLVE** agarose powder by boiling the solution. **MICROWAVE** the solution on high for 1 minute. Carefully **REMOVE** the flask from the microwave and **MIX** by swirling the flask. Continue to **HEAT** the solution in 15-second bursts until the agarose is completely dissolved (the solution should be clear like water).
4. **COOL** agarose to 60 °C with careful swirling to promote even dissipation of heat. 
5. While agarose is cooling, **SEAL** the ends of the gel-casting tray with the rubber end caps. **PLACE** the well template (comb) in the appropriate notch.
6. Before casting the gel, **ADD diluted SYBR® Safe** to the cooled agarose and swirl to mix (see Table A.2).
7. **POUR** the cooled agarose solution into the prepared gel-casting tray. The gel should thoroughly solidify within 20 minutes. The gel will stiffen and become less transparent as it solidifies.
8. **REMOVE** end caps and comb. Take particular care when removing the comb to prevent damage to the wells.

Size of Gel Casting tray	Concentrated Buffer (50x)	Distilled Water	Amt of Agarose	= TOTAL Volume	Diluted SYBR® (Step 6)
7 x 7 cm	0.6 mL	29.4 mL	0.24 g	30 mL	30 µL
10 x 7 cm*	0.9 mL	44.1 mL	0.36 g	45 mL	45 µL
14 x 7 cm	1.2 mL	58.8 mL	0.48 g	60 mL	60 µL

\* Recommended gel volume for the EDGE™ Integrated Electrophoresis System.

PROCEED to Loading and Running the Gel (Steps 8-12 on page 11), followed by the VISUALIZATION procedures on page 24. **NO ADDITIONAL STAINING IS NECESSARY.**

## Appendix C

### Using SYBR® Safe DNA Stain (OPTIONAL)

#### VISUALIZING THE SYBR® GEL

A blue light or UV transilluminator is needed for visualizing SYBR® gels. The TruBlu™ 2 ([Cat. #557](#)) is highly recommended.

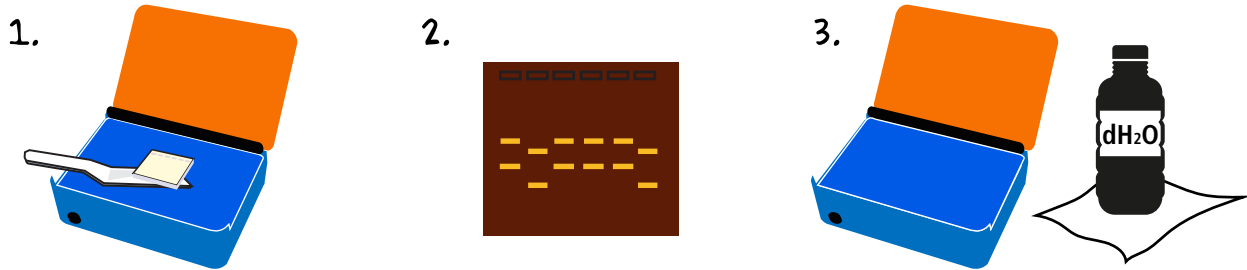

1. **SLIDE** gel off the casting tray onto the viewing surface of the transilluminator.
2. Turn the unit **ON**. DNA should appear as bright green bands on a dark background. **PHOTOGRAPH** results.
3. Turn the unit **OFF**. **REMOVE** and **DISPOSE** of the gel. **CLEAN** the transilluminator surfaces with distilled water.

