

Edvo-Kit #

122

Edvo-Kit #122

Detection of the Influenza Virus

Experiment Objective:

The Influenza virus, or “the flu”, is a common contagious disease that affects the respiratory system. In this simulation, students will perform two common tests (RIDT, RT-PCR) used to diagnose the flu in a clinical setting.

See page 3 for storage instructions.

Version 122.210628

EDVOTEK®

Table of Contents

	Page
Experiment Components	3
Experiment Requirements	4
Background Information	5
Experiment Procedures	
Experiment Overview	9
Module I: Patient History	10
Module II: Rapid Influenza Diagnostic Test	11
Module III: Agarose Gel Electrophoresis	12
Module IV: Staining Agarose Gels Using FlashBlue™	15
Module V: Data Analysis Using a Standard Curve	16
Study Questions	19
Instructor's Guidelines	20
Pre-Lab Preparations	21
Experiment Results and Analysis	24
Study Questions and Answers	25
Appendices	26
A EDVOTEK® Troubleshooting Guide	27
B Bulk Preparation of Electrophoresis Buffer and Agarose Gels	28
C Using SYBR® Safe Stain (OPTIONAL)	29

Safety Data Sheets can be found on our website: www.edvotek.com/safety-data-sheets

Technical Support

1.800.EDVOTEK

Mon. - Fri. 8 AM to 5:30 PM EST



Please Have the Following Info:

- Product Number & Description
- Lot Number on Box
- Order/Purchase Order #

1.800.EDVOTEK • info@edvotek.com • www.edvotek.com

www.edvotek.com

- Online Catalog
- Order Products
- Experiment Protocols
- Tech Support
- Resources!



EDVOTEK and The Biotechnology Education Company are registered trademarks of EDVOTEK, Inc. Ready-to-Load, QuickStrip, FlashBlue, and UltraSpec-Agarose are trademarks of EDVOTEK, Inc. SYBR is a registered trademark of Thermo Fisher Scientific.



1.800.EDVOTEK • Fax 202.370.1501 • info@edvotek.com • www.edvotek.com

Duplication of any part of this document is permitted for non-profit educational purposes only. Copyright © 1989-2021 EDVOTEK, Inc., all rights reserved. Version 122.210628

Experiment Components

MODULE I is a dry activity (page 10).

MODULE II

Components	Storage	Check (✓)
A Simulated Antibody Solution	4 °C	<input type="checkbox"/>
B Negative Control	4 °C	<input type="checkbox"/>
C Positive Control	4 °C	<input type="checkbox"/>
D Patient 1 Sample	4 °C	<input type="checkbox"/>
E Patient 2 Sample	4 °C	<input type="checkbox"/>
F Patient 3 Sample	4 °C	<input type="checkbox"/>

Experiment #122 is designed for 8 groups.

Store QuickStrip™ samples in the refrigerator upon receipt.

MODULE III

Store QuickStrip™ samples in the refrigerator immediately upon receipt.

A DNA Standard Marker	Refrigerator	<input type="checkbox"/>
B Negative Control	Refrigerator	<input type="checkbox"/>
C Positive Control	Refrigerator	<input type="checkbox"/>
D Patient 1 Sample	Refrigerator	<input type="checkbox"/>
E Patient 2 Sample	Refrigerator	<input type="checkbox"/>
F Patient 3 Sample	Refrigerator	<input type="checkbox"/>

REAGENTS & SUPPLIES

Store the following at room temperature.

- Rapid Influenza Diagnostic Test (RIDT) Strips
- Microtipped Transfer Pipets
- UltraSpec-Agarose™
- Electrophoresis Buffer (50x)
- Practice Gel Loading Solution
- FlashBlue™ DNA Stain

All experiment components are intended for educational research only. They are not to be used for diagnostic or drug purposes, nor administered to or consumed by humans or animals.

Requirements

- Horizontal gel electrophoresis apparatus
- D.C. power supply
- Automatic micropipettes with tips
- Balance
- Microwave, hot plate or burner
- Pipet pump
- 250 mL flasks or beakers
- Hot gloves
- Safety goggles and disposable laboratory gloves
- Small plastic trays or large weigh boats (for gel destaining)
- DNA visualization system (white light)
- Distilled or deionized water



Background Information

THE INFLUENZA VIRUS

Every winter, people around the world prepare themselves for cold weather, long nights, and the flu season. Influenza, or “the flu”, is a common contagious disease that affects the respiratory system. Symptoms of the flu generally last about one week, and may include fever and chills, sore throat, severe headaches, coughing, weakness, and muscle aches. Most cases of the flu are treated with rest, fluids and a fever-reducing drug like acetaminophen or ibuprofen. Complications related to the flu can cause death in young children, pregnant women, the elderly, and individuals with compromised immune systems.

The yearly seasonal flu epidemic in the United States is caused by one of two species of Orthomyxovirus known as *Influenzavirus A* or *B* (Figure 1). An influenza particle, or virion, is roughly spherical in shape, measuring about 80-120 nanometers in diameter. A special layer of proteins, called the capsid, surrounds and protects the eight pieces of RNA that make up the viral genome. Surface proteins called hemagglutinin (HA) and neuraminidase (NA) protrude from the viral envelope (a layer of proteins and lipids that surrounds the capsid). These proteins allow the virus to target and invade cells during an infection.

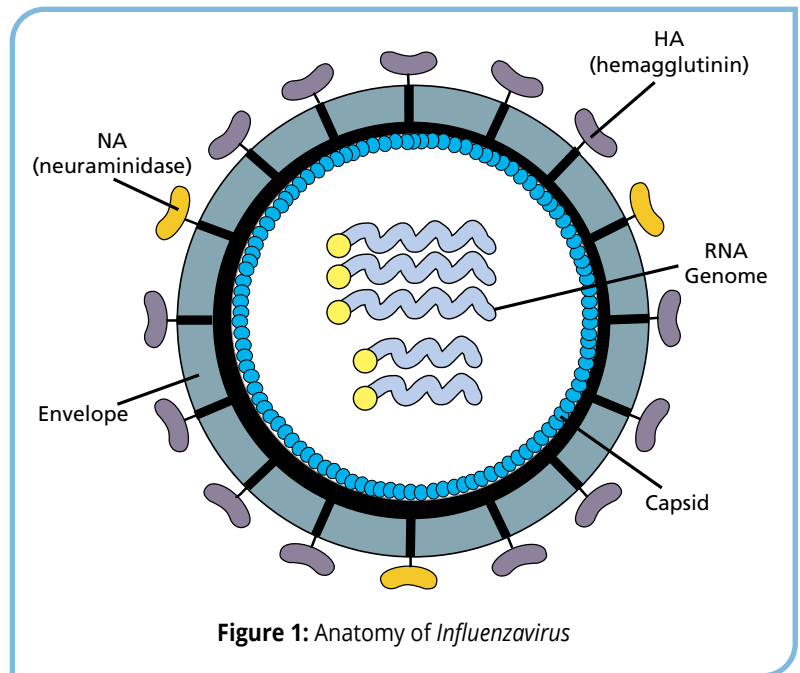

Figure 1: Anatomy of *Influenzavirus*

Subtypes of influenza A are characterized by the combination of HA and NA proteins present on the surface of the virus. There are 16 variants of the HA protein and nine variants of NA, but only a few of these variants are generally found in viruses that infect humans. For example, the most common flu virus in the United States in 2012 utilized HA variant three and NA variant two. Accordingly, it is named Influenza A (H₃N₂). Influenza B is not separated into subtypes by HA and NA variants; instead, strains are classified by changes in the RNA genome.

Luckily, with proper precautions, it is easy to prevent the flu. As the virus is found in respiratory mucus, coughs and sneezes can spread the flu through the air, contaminating surfaces (like door handles) and people. Soap, hand sanitizer and other disinfectants kill the flu virus, so frequent washing of hands can limit its spread. Touching your face with contaminated hands can introduce the flu virus to your mucus membranes, so it is important to keep hands away from your eyes, nose and mouth.

Furthermore, scientists predict which three strains of influenza will be most common in a particular flu season and formulate a yearly vaccine to combat them. In 2012, the vaccine was proven to be about 62% effective. In fact, the CDC reports that the three viruses used to create this vaccine were responsible for 90% of reported cases of the flu during the 2012-2013 flu season. Studies are currently underway to create a universal flu vaccine.

DIAGNOSING THE FLU

As a general rule, symptoms of the flu are enough to warrant its diagnosis, especially during flu season. However, sometimes further testing is necessary to rule out more serious conditions, like pneumonia. Additionally, epidemiologists may test patient samples (like nasal mucus) to determine which subtypes of the flu are responsible for an epidemic. To quickly detect the presence of the flu virus in these samples, scientists use the Enzyme-Linked Immunosorbent Assay (or ELISA). This technique utilizes antibodies to recognize an antigen of interest in a complex sample (summarized in Figure 2).

In brief, the patient sample is added to the wells of a plastic plate, where it non-specifically adheres to the wells through hydrophobic and electrostatic interactions. After washing away any excess sample, the wells are "blocked" with a protein-containing buffer to prevent non-specific interactions between the antibody and the plastic wells. Next, the primary antibody is added to the wells. This primary antibody will recognize and bind to the virion's coat proteins. After an incubation period, the wells are washed to remove any primary antibody that did not bind. The secondary antibody is added to the wells where it recognizes and binds to the primary antibody. Excess antibody is removed from the wells by washing several times with buffer. If the secondary antibody has bound to the primary antibody, it will remain in the well.

The secondary antibody has been covalently linked to an enzyme that allows us to detect the antibody-antigen interactions. A clear, colorless substrate solution is added to each of the wells. In wells where the secondary antibody is present, the enzymatic reaction changes the substrate solution from clear to brown. Since the enzyme has a high catalytic activity, the ELISA can detect even the smallest amount of antigen.

Unfortunately, the ELISA can take several hours to perform. This is a problem if a doctor needs to quickly decide upon a course of treatment (for example, antiviral medications versus antibiotics). To address this problem, scientists developed the rapid influenza diagnostic test (RIDT), an immunoassay that can detect the flu in a doctor's office in less than thirty minutes. The clinician will spot the patient sample onto a test strip onto which an influenza detection antibody has been chemically linked. After a short incubation, if the patient sample is positive for viral antigens, the white test strip will change to a bright pink color.

Although the RIDT is fast, it is not without flaws. In the laboratory, the antibody used in the RIDT has a robust, reproducible interaction with the viral antigens. In practice, this assay has a high rate of false positive results -- it may misdiagnose the flu in up to 30% of cases! This variability is due to poor sample preparation and seasonal variation in the HA and NA proteins. As such, a second method of flu detection is necessary.

USING PCR TO DIAGNOSIS INFLUENZA

In 1984, Dr. Kary Mullis revolutionized the field of molecular biology when he devised a simple and elegant method to copy specific pieces of DNA. Mullis recognized that he could replicate DNA in vitro using short, synthetic DNA oligonucleotides (known as primers) and DNA Polymerase I in a process similar to DNA replication in a cell's nucleus. Furthermore, because researchers can customize the primers to target a specific gene, this method would allow for the rapid amplification of a selected DNA sequence. For the development of this technique, known today as the Polymerase Chain Reaction (or PCR), Mullis was awarded the Nobel Prize in Chemistry in 1993.

To perform PCR, purified double-stranded DNA is mixed with primers, a thermostable DNA polymerase (Taq) and nucleotides. Then, the mixture is heated to 94°C to denature the DNA duplex (i.e., unzip it into single strands). Next, the sample is then cooled to 45°C-60°C, allowing the primers to base pair with the target DNA sequence (called "annealing"). Lastly, the

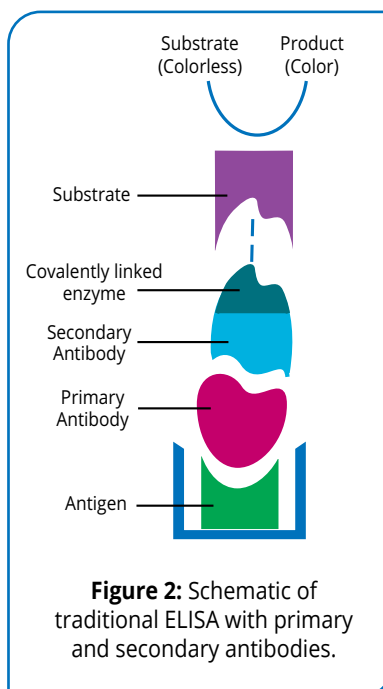

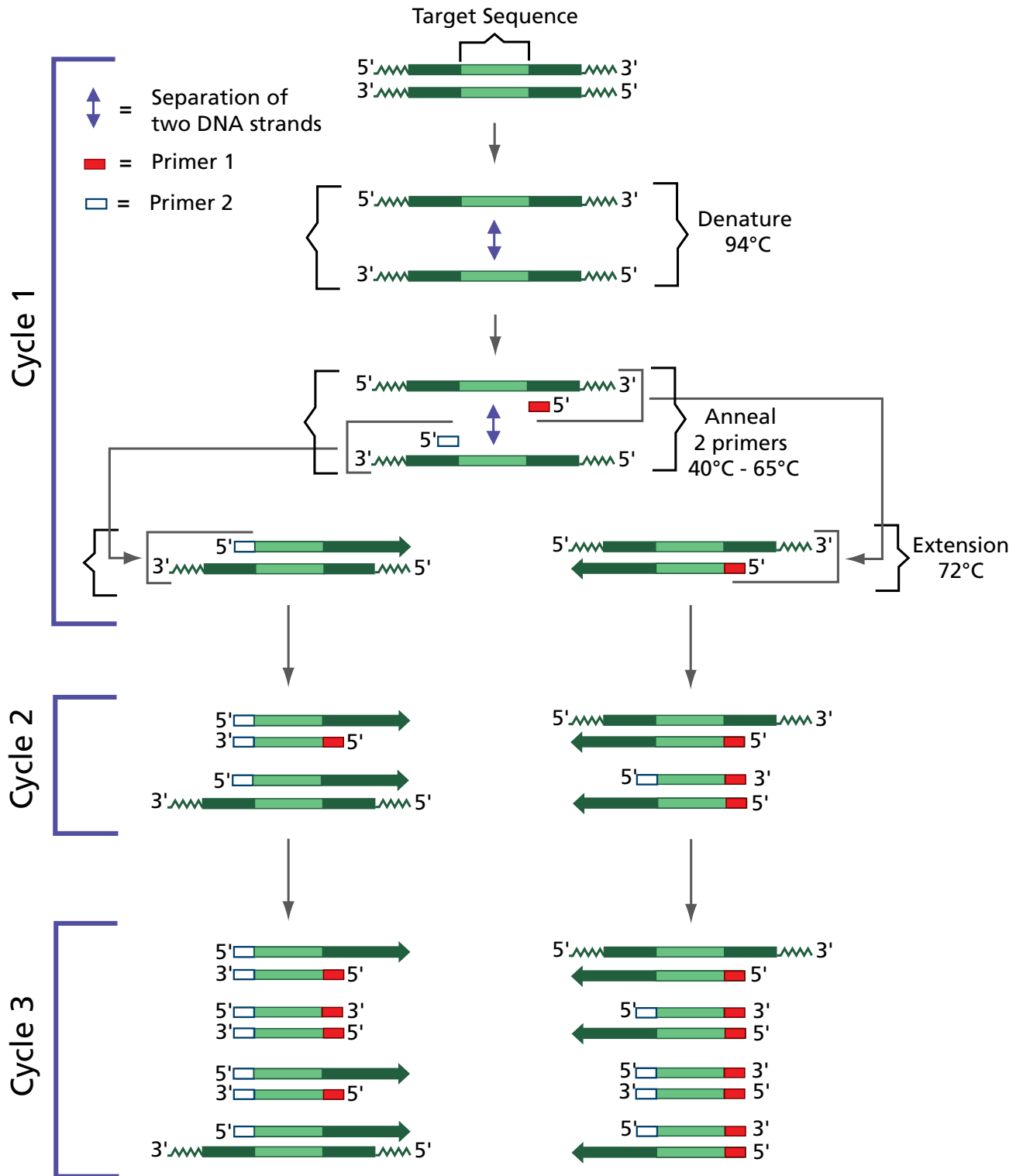

Figure 3:
DNA Amplification by the Polymerase Chain Reaction

temperature is raised to 72°C, the optimal temperature at which Taq polymerase will extend the primer to synthesize a new strand of DNA. Each “PCR cycle” (denaturation, annealing, extension) doubles the amount of the target DNA in less than five minutes (summarized in Figure 3). In order to produce enough DNA for analysis, twenty to forty cycles may be required. To simplify this process, a specialized machine, called a “thermal cycler” or a “PCR machine”, was created to rapidly heat and cool the samples.

Because of its ease of use and its ability to rapidly amplify DNA, PCR has become indispensable in medical diagnostic laboratories for the detection of pathogens. Unfortunately, since *Taq* polymerase is a DNA-dependent DNA polymerase, it cannot use the RNA genome of *Influenzavirus* as a template. In order to detect the flu using PCR, Reverse Transcriptase (RT) is used to synthesize complementary DNA (cDNA) copies of the RNA genome. A small amount of the cDNA is mixed with Taq polymerase, dNTPs and primers for amplification by PCR. Because RT-PCR is extremely sensitive and can detect very low levels of the virus, as well as differentiate influenza A from influenza B, it is considered the “gold standard” for influenza detection. However, since RT-PCR tests for the flu are performed in a medical diagnostic laboratory, it may take several days to get the results, even though the actual test takes a few hours.

The primers used in this RT-PCR experiment are designed to produce DNA fragments of different lengths depending upon whether the flu virus is present in a patient sample. As an internal control, a human housekeeping gene is simultaneously amplified. In order to analyze this sample, scientists use a technique called agarose gel electrophoresis to separate DNA fragments according to size. The mixture of DNA molecules is added into depressions (or “wells”) within a gel, and then an electrical current is passed through the gel. Because the sugar-phosphate backbone of DNA has a strong negative charge, the current drives the DNA through the gel towards the positive electrode (Figure 4A).

At first glance, an agarose gel appears to be a solid at room temperature. On the molecular level, the gel contains small channels through which the DNA can pass. Small DNA fragments move through these holes easily, but large DNA fragments have a more difficult time squeezing through the tunnels. Because molecules with dissimilar sizes travel at different speeds, they become separated and form discrete “bands” within the gel. After the current is stopped, the bands can be visualized using a stain that sticks to DNA (Figure 4B).

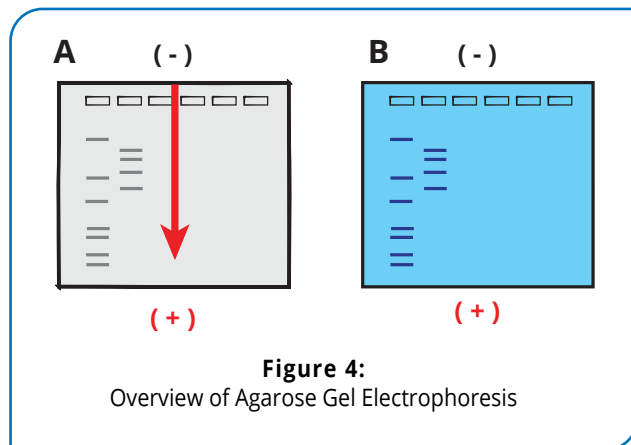

Figure 4:
Overview of Agarose Gel Electrophoresis

Experiment Overview

EXPERIMENT OBJECTIVE

The Influenza virus, or “the flu”, is a common contagious disease that affects the respiratory system. In this simulation, students will perform two common tests (RIDT, RT-PCR) used to diagnose the flu in a clinical setting.

LABORATORY SAFETY

1. Gloves and goggles should be worn routinely as good laboratory practice.
2. Exercise extreme caution when working with equipment that is used in conjunction with the heating and/or melting of reagents.
3. DO NOT MOUTH PIPET REAGENTS - USE PIPET PUMPS.
4. Exercise caution when using any electrical equipment in the laboratory.
5. Always wash hands thoroughly with soap and water after handling reagents or biological materials in the laboratory.



LABORATORY NOTEBOOKS

Scientists document everything that happens during an experiment, including experimental conditions, thoughts and observations while conducting the experiment, and, of course, any data collected. Today, you'll be documenting your experiment in a laboratory notebook or on a separate worksheet.

Before starting the Experiment:

- Carefully read the introduction and the protocol. Use this information to form a hypothesis for this experiment.
- Predict the results of your experiment.

During the Experiment:

- Record your observations.

After the Experiment:

- Interpret the results – does your data support or contradict your hypothesis?
- If you repeated this experiment, what would you change? Revise your hypothesis to reflect this change.

Module I: Patient History

REVIEW this Patient History **BEFORE** performing the experiment.

Three patients were examined in the doctor's office, and the following symptoms were identified.

Patient 1 17 year old female, complaint of sore throat, runny nose and headache. High school has reported several cases of the flu.

Patient 2 30 year old male, symptoms include sore throat, weakness and cough. A persistent fever of 103 °F has been recorded.

Patient 3 46 year old male, symptoms include congestion, muscle aches and cough.

Each patient has several symptoms, some which are indicative of the flu. Because of these symptoms, and because there is a known influenza outbreak in the area, the primary care physician has recommended further testing before a diagnosis can be made. **RECORD** any symptoms that suggest influenza in Table 1 before performing the medical tests.

TABLE 1: PATIENT MEDICAL RECORDS

Sample	Symptoms	RIDT	RT-PCR	Diagnosis
Patient 1				
Patient 2				
Patient 3				

Module II: Rapid Influenza Diagnostic Test

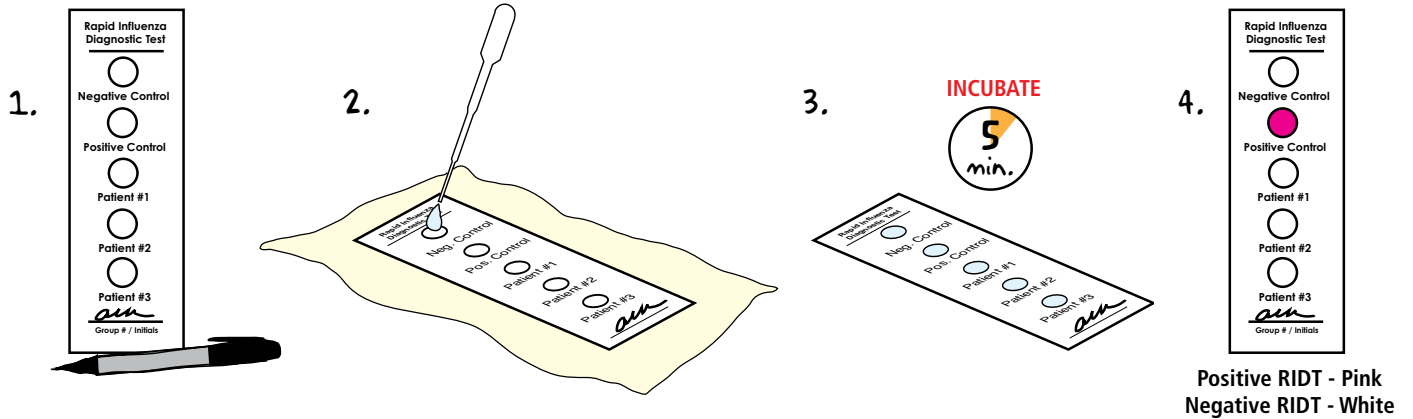

1. **LABEL** the RIDT Strip with your group number. **PLACE** your test strip on top of a paper towel.
2. **PLACE** one drop of the control or patient samples onto the appropriate circle on the strip. **NOTE: Be sure to use a fresh transfer pipet for each sample.**
3. **INCUBATE** the strip for 5 minutes at room temperature.
4. **EXAMINE** the samples. Negative samples will remain white, while positive samples will turn bright pink. **RECORD** the results in Table 1 on page 10.

Overview of Electrophoresis & Staining

MODULE III: Agarose Gel Electrophoresis

Time required: See Table C

Quick Reference for EDVO-Kit #122			
Size of gel casting tray	Groups per gel	Placement of comb	Wells required per group
7 x 7 cm	1 group	1st set of notches	6
10 x 7 cm	1 group	1st set of notches	6
14 x 7 cm	2 groups	1st and 3rd sets of notches	6

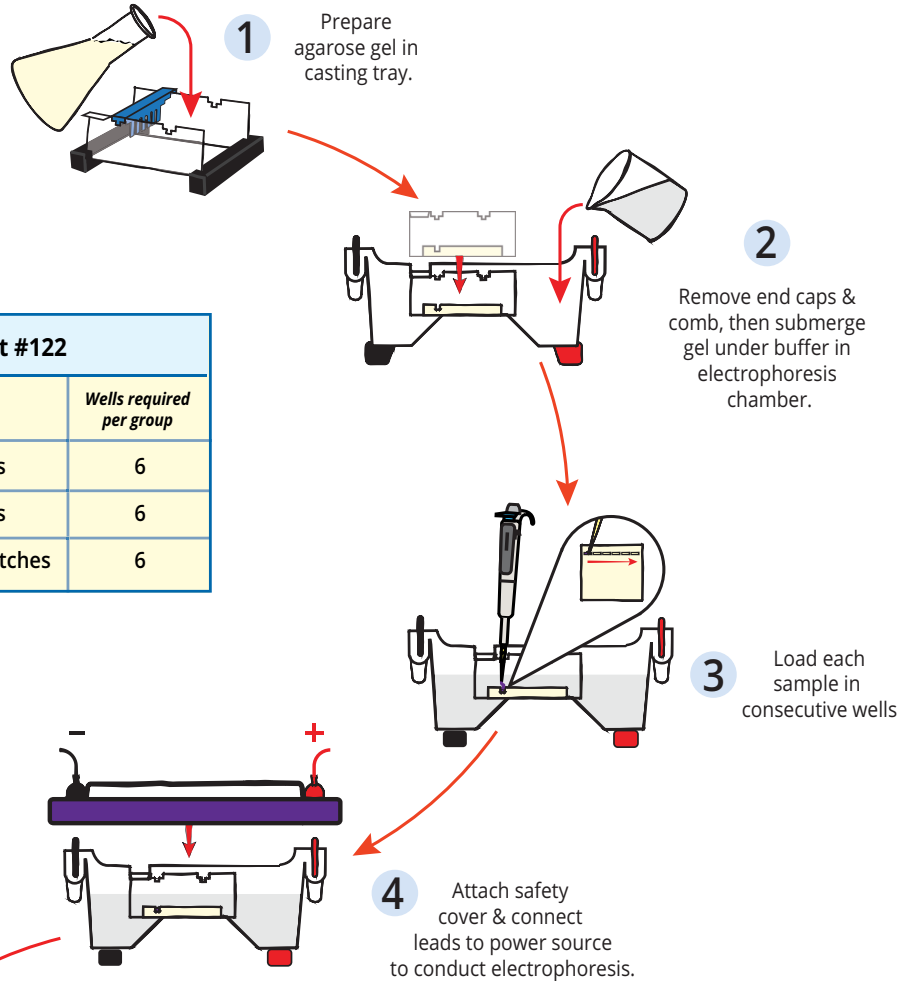

MODULE IV: Staining Agarose Gels Using FlashBlue™

Time required: 30 min.

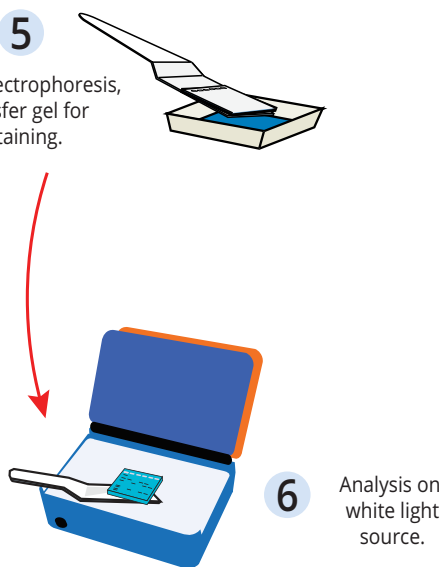

Related EDVOTEK® Instructional Videos

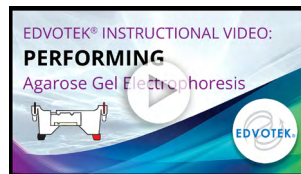
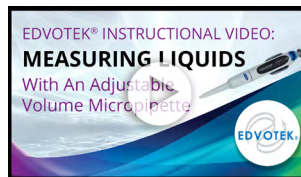

www.youtube.com/edvotekinc

Module III: Agarose Gel Electrophoresis

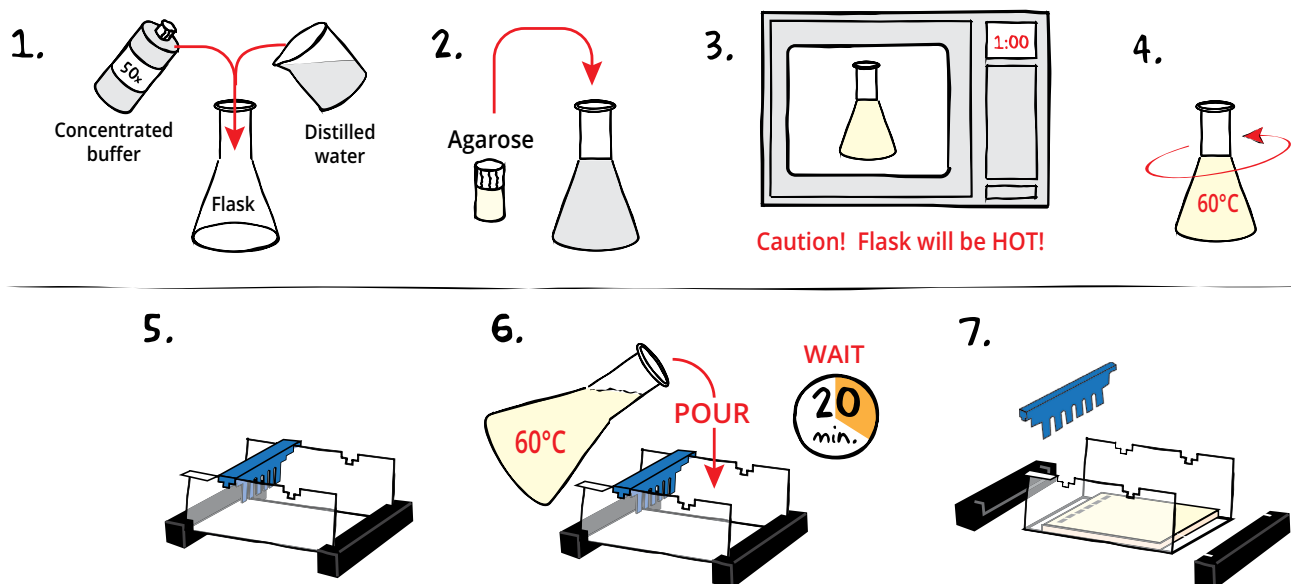

CASTING THE AGAROSE GEL

- DILUTE** concentrated 50X Electrophoresis buffer with distilled water (refer to Table A for correct volumes depending on the size of your gel casting tray).
- MIX** agarose powder with buffer solution in a 250 mL flask (refer to Table A).
- DISSOLVE** agarose powder by boiling the solution. **MICROWAVE** the solution on high for 1 minute. Carefully **REMOVE** the flask from the microwave and **MIX** by swirling the flask. Continue to **HEAT** the solution in 15-second bursts until the agarose is completely dissolved (the solution should be clear like water).
- COOL** agarose to 60 °C with careful swirling to promote even dissipation of heat.
- While agarose is cooling, **SEAL** the ends of the gel-casting tray with the rubber end caps. **PLACE** the well template (comb) in the appropriate notch.
- POUR** the cooled agarose solution into the prepared gel-casting tray. The gel should thoroughly solidify within 20 minutes. The gel will stiffen and become less transparent as it solidifies.
- REMOVE** end caps and comb. Take particular care when removing the comb to prevent damage to the wells.



Wear gloves and safety goggles

REMINDER:
This experiment requires 0.8% agarose gels cast with 6 wells.

Table A Individual 0.8% UltraSpec-Agarose™ Gels				
Size of Gel Casting tray	Concentrated Buffer (50x)	+ Distilled Water	+ Amt of Agarose	= TOTAL Volume
7 x 7 cm	0.6 mL	29.4 mL	0.24 g	30 mL
10 x 7 cm*	0.9 mL	44.1 mL	0.36 g	45 mL
14 x 7 cm	1.2 mL	58.8 mL	0.48 g	60 mL

*Recommended gel volume for the EDGE™ Integrated Electrophoresis System. (Cat. #500).

Module III: Agarose Gel Electrophoresis

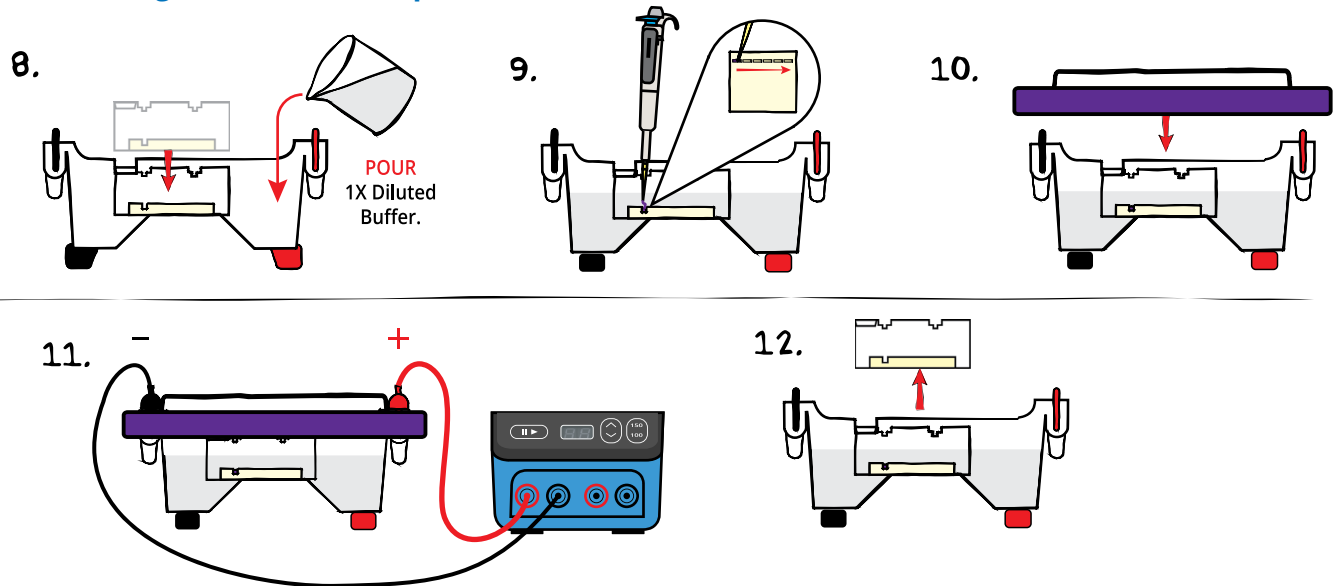

RUNNING THE GEL

- PLACE** the gel (still on the tray*) into the electrophoresis chamber. **COVER** the gel with 1X Electrophoresis Buffer (See Table B for recommended volumes). The gel should be completely submerged.
- PUNCTURE** the foil overlay of the QuickStrip™ with a pipet tip. **LOAD** the entire sample (35 µL) into the well in the order indicated by Table 2, at right.
- PLACE** safety cover on the unit. **CHECK** that the gel is properly oriented. Remember, the DNA samples will migrate toward the positive (red) electrode.
- CONNECT** leads to the power source and **PERFORM** electrophoresis (See Table C for time and voltage guidelines). Allow the tracking dye to migrate at least 3 cm from the wells.
- After electrophoresis is complete, **REMOVE** the gel and casting tray from the electrophoresis chamber.

REMINDER:
Before loading the samples, make sure the gel is properly oriented in the apparatus chamber.

TABLE 2: GEL LOADING

Lane	Tube	Sample
1	Tube A	DNA Standard Marker
2	Tube B	Negative Control
3	Tube C	Positive Control
4	Tube D	Patient 1
5	Tube E	Patient 2
6	Tube F	Patient 3

Table B
1x Electrophoresis Buffer (Chamber Buffer)

EDVOTEK Model #	Total Volume Required	Dilution	
		50x Conc. Buffer	+ Distilled Water
EDGE™	150 mL	3 mL	147 mL
M12	400 mL	8 mL	392 mL
M36	1000 mL	20 mL	980 mL

Table C
Time and Voltage Guidelines (0.8% Agarose Gel)

Volts	Electrophoresis Model	
	EDGE™	M12 & M36
	Min/Max (minutes)	Min/Max (minutes)
150	10/20	20/35
125	N/A	30/45
100	15/25	40/60

*Gels that have previously been removed from their trays should be "anchored" back to the tray with a few drops of molten agarose before placing into the electrophoresis chamber. This will prevent the gels from sliding around in the trays and the chambers.

Module IV: Staining Agarose Gels Using FlashBlue™

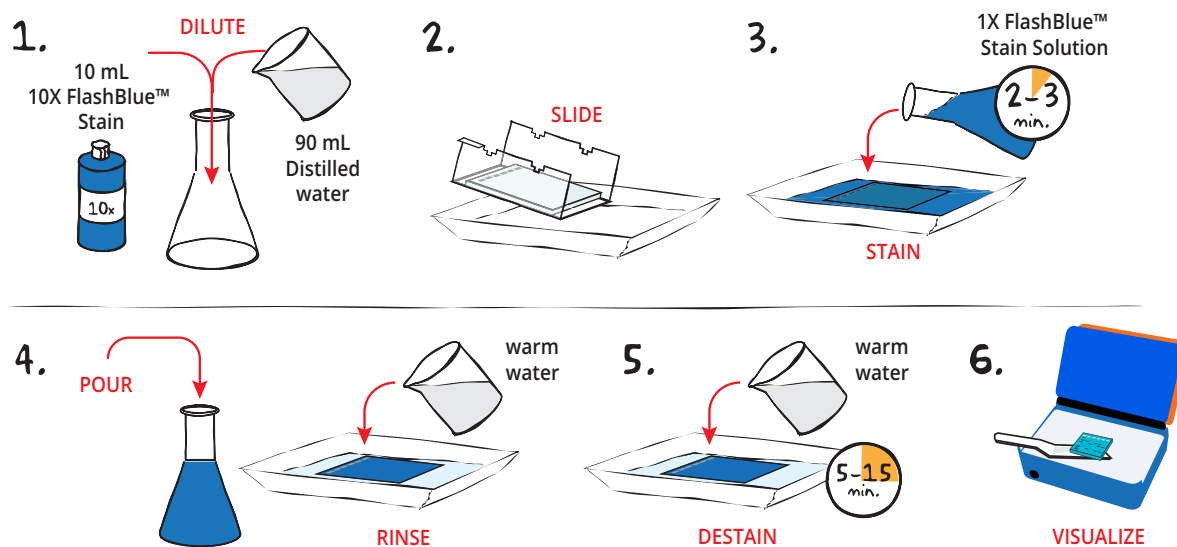

- DILUTE** 10 mL of 10X concentrated FlashBlue™ with 90 mL of distilled water in a flask. **MIX** well.
- REMOVE** the agarose gel and casting tray from the electrophoresis chamber. **SLIDE** the gel off the casting tray into a small, clean gel-staining tray.
- COVER** the gel with the 1X FlashBlue™ stain solution. **STAIN** the gel for 2-3 minutes. For best results, use an orbital shaker to gently agitate the gel while staining. **STAINING THE GEL FOR LONGER THAN 3 MINUTES WILL REQUIRE EXTRA DESTAINING TIME.**
- POUR** the 1X FlashBlue™ back into the flask (the stain can be reused). **COVER** the gel with warm water (40-45 °C). Gently **RINSE** the gel for 20-30 seconds. **POUR** off the water.
- COVER** the gel with clean, warm water (40-45 °C). **DESTAIN** for 5-15 minutes with gentle shaking (longer periods will yield better results). DNA bands will start to appear after 5 minutes of destaining. Changing the water frequently will accelerate destaining.
- Carefully **REMOVE** the gel from the destaining liquid. **VISUALIZE** results using a white light visualization system. DNA will appear as dark blue bands on a light blue background.



ALTERNATIVE FLASHBLUE™ STAINING PROTOCOL:

- DILUTE** 1 mL of 10X FlashBlue™ stain with 149 mL distilled water.
- COVER** the gel with diluted FlashBlue™ stain.
- SOAK** the gel in the staining liquid for at least three hours. For best results, stain gels overnight.
- Carefully **REMOVE** the gel from the staining liquid. **VISUALIZE** results using a white light visualization system. DNA will appear as dark blue bands on a light blue background.

Module V: Data Analysis Using a Standard Curve

Agarose gel electrophoresis separates biomolecules into discrete bands, each comprising molecules of the same size. How can these results be used to determine the lengths of different fragments? Remember, as the length of a biomolecule increases, the distance to which the molecule can migrate decreases because large molecules cannot pass through the channels in the gel with ease. Therefore, the migration rate is inversely proportional to the length of the molecules—more specifically, to the \log_{10} of molecule's length. To illustrate this, we ran a sample that contains bands of known lengths called a "standard". We will measure the distance that each of these bands traveled to create a graph, known as a "standard curve", which can then be used to extrapolate the size of unknown molecule(s).



Figure 5: Measure distance migrated from the lower edge of the well to the lower edge of each band.

1. Measure and Record Migration Distances

Measure the distance traveled by each Standard DNA Fragment from the lower edge of the sample well to the lower end of each band. Record the distance in centimeters (to the nearest millimeter) in your notebook. Repeat this for each DNA fragment in the standard.

Measure and record the migration distances of each of the fragments in the unknown samples in the same way you measured the standard bands.

2. Generate a Standard Curve

Because migration rate is inversely proportional to the \log_{10} of band length, plotting the data as a semi-log plot will produce a straight line and allow us to analyze an exponential range of fragment sizes. You will notice that the vertical axis of the semi-log plot appears atypical at first; the distance between numbers shrinks as the axis progresses from 1 to 9. This is because the axis represents a logarithmic scale. The first cycle on the y-axis corresponds to lengths from 100-1,000 base pairs, the second cycle measures 1,000-10,000 base pairs, and so on. To create a standard curve on the semi-log paper, plot the distance each Standard DNA fragment migrated on the x-axis (in mm) versus its size on the y-axis (in base pairs). Be sure to label the axes!

Figure 6: Semilog graph example

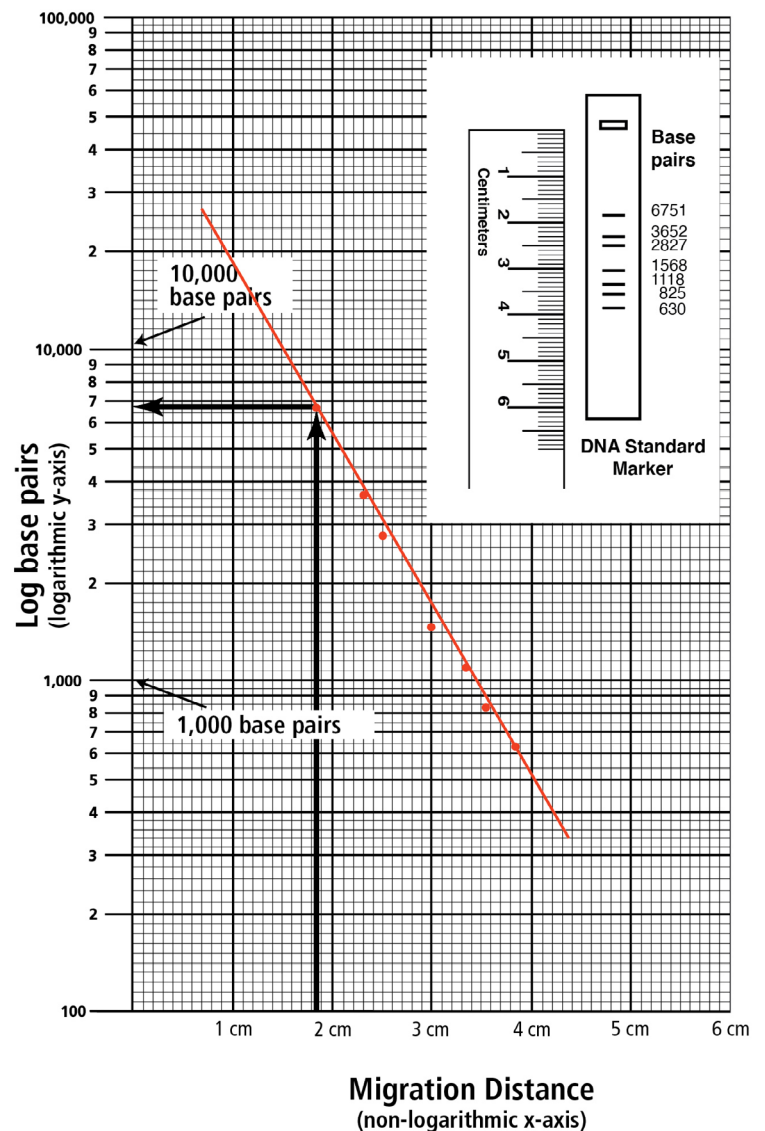

Module V: Data Analysis Using a Standard Curve

After all the points have been plotted, use a ruler or a straight edge to draw the best straight line possible through the points. The line should have approximately equal numbers of points scattered on each side of the line. It is okay if the line runs through some points (see Figure 6 for an example).

Quick Reference:

DNA Standard fragment sizes - length is expressed in base pairs.

6751, 3652, 2827, 1568,
1118, 825, 630

3. Determine the length of each unknown fragment.

- Locate the migration distance of the unknown fragment on the x-axis of your semi-log graph. Draw a vertical line extending from that point until it intersects the line of your standard curve.
- From the point of intersection, draw a second line, this time horizontally, toward the y-axis. The value at which this line intersects the y-axis represents the approximate size of the fragment in base pairs (refer to Figure 6 for an example). Make note of this in your lab notebook.
- Repeat for each fragment in your unknown sample.

Includes EDVOTEK's All-NEW DNA Standard Marker

- Better separation
- Easier band measurements
- No unused bands

**NEW DNA Standard ladder sizes:
6751, 3652, 2827, 1568, 1118, 825, 630**



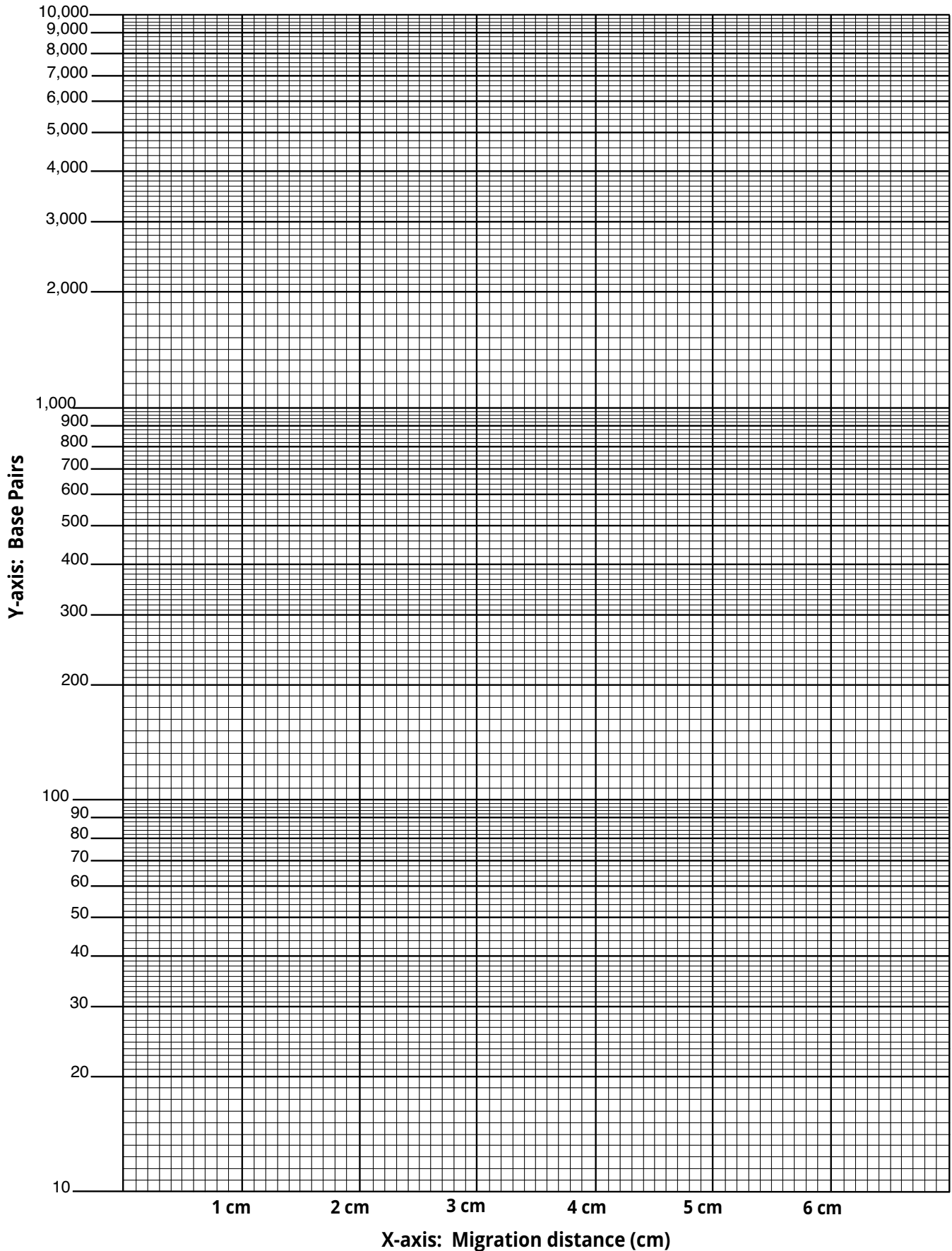

1.800.EDVOTEK • Fax 202.370.1501 • info@edvotek.com • www.edvotek.com

Duplication of any part of this document is permitted for non-profit educational purposes only. Copyright © 1989-2021 EDVOTEK, Inc., all rights reserved. Version 122.210628

Study Questions

1. What kind of virus is the flu? How do scientists distinguish between subtypes of the flu?
2. What tests are used to identify the flu? What are the advantages and disadvantages?
3. What is Reverse Transcriptase and how does it work? Why is it important for detecting the flu in patient samples?
4. You have collected a medical history from three different patients and performed the RIDT and RT-PCR tests on samples from them. Knowing their test results and the patient medical history, make a diagnosis for each of the patients.

Instructor's Guide

ADVANCE PREPARATION:

Preparation for:	What to do:	When?	Time Required:
Module I: Patient History	Photocopy/print patient history table	Before the class period	5 min.
Module II: Rapid Influenza Detection Test	Prepare Test Strips	One week to one day before performing the experiment	30 min.
	Prepare and aliquot Reagents	One week to one day before performing the experiment	30 min.
Module III: Agarose Gel Electrophoresis	Prepare QuickStrips™	Up to one day before performing the experiment	45 min.
	Prepare diluted electrophoresis buffer		
	Prepare molten agarose and pour gels		
Module IV: Staining Agarose Gels	Prepare staining components	The class period or overnight after the class period	10 min.

Technical Support

1.800.EDVOTEK

Mon. - Fri. 8 AM to 5:30 PM EST



Please Have the Following Info:

- Product Number & Description
- Lot Number on Box
- Order/Purchase Order #

1.800.EDVOTEK • info@edvotek.com • www.edvotek.com

www.edvotek.com

- Online Catalog
- Order Products
- Experiment Protocols
- Tech Support
- Resources!



Pre-Lab Preparations

MODULE I: PATIENT HISTORY

- Print or photocopy patient history page.
- Students will record the patient histories in the provided table or a similar table in the student's notebook.

MODULE II: RAPID INFLUENZA DIAGNOSTIC TEST

Preparation of the Rapid Influenza Diagnostic Test (RIDT) Strips (One week to one hour before experiment)

1. Place the paper sheet containing the RIDT Strips on a paper towel.
2. Apply one drop (or 20 μ L) of the Simulated Antibody Solution (Module II, Component A) onto each of the circles.
3. Allow the strips to completely dry.
4. Cut the RIDT Strips along the solid lines.

FOR MODULE II
Each group will need:

- 1 tube for each of the following:
+, -, P1, P2, and P3
- 1 prepared RIDT Strip
- 5 transfer pipets

Preparation of Patient Samples

1. Label forty 1.5 mL snap-top microcentrifuge tubes as follows:
 - 8 tubes "+" (Positive Control)
 - 8 tubes "-" (Negative Control)
 - 8 tubes "P1" (Patient 1)
 - 8 tubes "P2" (Patient 2)
 - 8 tubes "P3" (Patient 3)
2. Use a separate large transfer pipet for dispensing each Module II component (B, C, D, E, F) to the appropriately labeled tube.
 - a. Fill each tube to the 0.5 mL mark on the side of the tube.
 - b. Cap the tubes and store at room temperature.

Pre-Lab Preparations

MODULE III: AGAROSE GEL ELECTROPHORESIS

This experiment requires 0.8% agarose gels. Enough reagents are provided to cast either eight 7 x 7 cm gels, eight 10 x 7 cm gels, or four 14 x 7 cm gels. You can choose whether to prepare the gels in advance or have students prepare their own. Allow approximately 30 minutes for this procedure.

Quick Reference for EDVO-Kit #122			
Size of gel casting tray	Groups per gel	Placement of comb	Wells required per group
7 x 7 cm	1 group	1st set of notches	6
10 x 7 cm	1 group	1st set of notches	6
14 x 7 cm	2 groups	1st and 3rd sets of notches	6

Individual Gel Preparation:

Each student group can be responsible for casting their own individual gel prior to conducting the experiment. See Module III in the Student's Experimental Procedure. Students will need 50x concentrated buffer, distilled water and agarose powder.

Batch Gel Preparation:

To save time, a larger quantity of agarose solution can be prepared for sharing by the class. Electrophoresis buffer can also be prepared in bulk. See Appendix B.

Preparing Gels in Advance:

Gels may be prepared ahead and stored for later use. Solidified gels can be stored under buffer in the refrigerator for up to 2 weeks.

Do not freeze gels at -20 °C as freezing will destroy the gels.

Gels that have been removed from their trays for storage should be "anchored" back to the tray with a few drops of molten agarose before being placed into the tray. This will prevent the gels from sliding around in the trays and the chambers.

SAMPLES FORMAT: PREPARING THE QUICKSTRIPS™

QuickStrip™ tubes consist of a microtiter block covered with a protective foil overlay. Each well contains pre-aliquoted sample.

Using sharp scissors, carefully divide the block of tubes into individual strips by cutting between the rows (see diagram at right). Take care not to damage the foil overlay while separating the samples.

Each lab group will receive one set of tubes. Before loading the gel, remind students to tap the tubes to collect the sample at the bottom of the tube. Puncture the foil overlay of the QuickStrip™ with a pipet tip to aspirate the sample. **Do not remove the foil as samples can spill.**

FOR MODULE III Each group will need:

- 50x concentrated buffer
- Distilled Water
- UltraSpec-Agarose™
- QuickStrip™ Samples

NOTE:

This kit is compatible with **SYBR® Safe Stain** (Cat #608, not included). Instructions for preparing gels and visualizing results can be found in Appendix C.

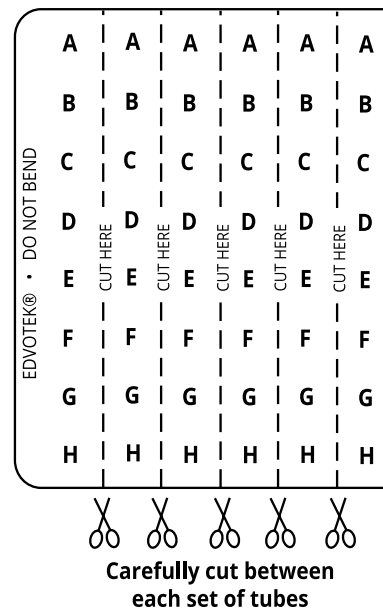

Pre-Lab Preparations

MODULE IV: STAINING AGAROSE GELS USING FLASHBLUE™

FlashBlue™ stain is optimized to shorten the time required for both staining and destaining steps. Agarose gels can be stained with diluted FlashBlue™ for 5 minutes and destained for only 20 minutes. For the best results, leave the gel in liquid overnight. This will allow the stained gel to “equilibrate” in the destaining solution, resulting in dark blue DNA bands contrasting against a uniformly light blue background. A white light box ([Cat. #552](#)) is recommended for visualizing gels stained with FlashBlue™.

- Stained gels may be stored in destaining liquid for several weeks with refrigeration, although the bands may fade with time. If this happens, re-stain the gel.
- Destained gels can be discarded in solid waste disposal. Destaining solutions can be disposed of down the drain.

FOR MODULE IV Each group will need:

- 10 mL 10X concentrated FlashBlue **OR**
100 mL 1x diluted FlashBlue
- Small plastic tray or weight boat
- Distilled or deionized water

PHOTODOCUMENTATION OF DNA (OPTIONAL)

Once gels are stained, you may wish to photograph your results. There are many different photodocumentation systems available, including digital systems that are interfaced directly with computers. Specific instructions will vary depending upon the type of photodocumentation system you are using.

NOTE:

Accurate pipetting is critical for maximizing successful experiment results. EDVOTEK Series 100 experiments are designed for students who have had previous experience with micropipetting techniques and agarose gel electrophoresis.

If students are unfamiliar with using micropipettes, we recommended performing [Cat. #S-44, Micropipetting Basics](#) or [Cat. #S-43, DNA DuraGel™](#) prior to conducting this experiment.

Experiment Results and Analysis

MODULE II:

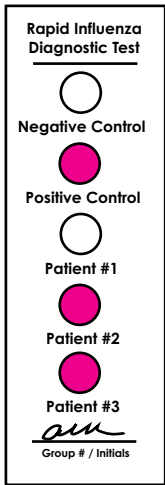

Sample	Result	Interpretation
Negative Control (-)	Clear	Negative
Positive Control (+)	Pink	Positive
Patient #1	Clear	Negative
Patient #2	Pink	Positive
Patient #3	Pink	Positive

MODULE III:

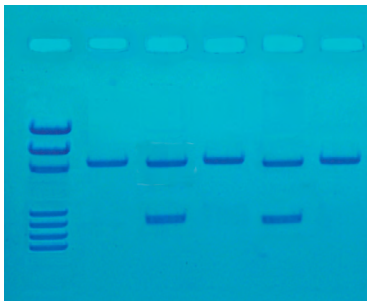

In the idealized schematic, the relative positions of DNA fragments are shown but are not depicted to scale.

Includes EDVOTEK's All-NEW DNA Standard Marker

- Better separation
- Easier band measurements
- No unused bands

NEW DNA Standard ladder sizes:
6751, 3652, 2827, 1568, 1118, 825, 630



Lane	Tube	Sample	Result	Molecular Weights (bp)
1	A	DNA Standard Markers	-----	6751, 3652, 2827, 1568 1118, 825, 630
2	B	Influenza Negative Control	Flu Negative	3000
3	C	Influenza Positive Control	Flu Positive	3000, 1280
4	D	Patient #1	Flu Negative	3000
5	E	Patient #2	Flu Positive	3000, 1280
6	F	Patient #3	Flu Negative	3000

**Please refer to the kit
insert for the Answers to
Study Questions**

Appendices

- A EDVOTEK® Troubleshooting Guide
- B Bulk Preparation of Electrophoresis Buffer and Agarose Gels
- C Using SYBR® Safe Stain (OPTIONAL)

Safety Data Sheets can be found on our website: www.edvotek.com/safety-data-sheets

Technical Support

1.800.EDVOTEK

Mon. - Fri. 8 AM to 5:30 PM EST



Please Have the Following Info:

- Product Number & Description
- Lot Number on Box
- Order/Purchase Order #

1.800.EDVOTEK • info@edvotek.com • www.edvotek.com

www.edvotek.com

- Online Catalog
- Order Products
- Experiment Protocols
- Tech Support
- Resources!



Appendix A

EDVOTEK® Troubleshooting Guides

PROBLEM:	CAUSE:	ANSWER:
Bands are not visible on the gel.	The gel was not prepared properly.	Ensure that the electrophoresis buffer was correctly diluted.
	The gel was not stained properly.	Repeat staining protocol.
	Malfunctioning electrophoresis unit or power source.	Contact the manufacturer of the electrophoresis unit or power source.
After staining the gel, the DNA bands are faint.	The gel was not stained for a sufficient period of time.	Repeat staining protocol.
	The background of gel is too dark after staining with FlashBlue™.	Destain the gel for 5-10 minutes in distilled water.
DNA bands were not resolved.	Tracking dye should migrate at least 3 cm from the wells to ensure adequate separation.	Be sure to run the gel at least 3 cm before staining and visualizing the DNA (approximately 15-20 minutes at 150 V).
DNA bands fade when gels are kept at 4 °C.	DNA stained with FlashBlue™ may fade with time.	Re-stain the gel with FlashBlue™.
There is no separation between DNA bands, even though the tracking dye ran the appropriate distance.	The wrong percent gel was used for electrophoretic separation.	Be sure to prepare the correct percent agarose gel. For reference, the Ready-to-Load™ DNA samples should be analyzed using a 0.8% agarose gel.
There's not enough sample in my QuickStrip™.	The QuickStrip™ has dried out.	Add 40 µL water, gently pipet up and down to mix before loading.

Visit www.edvotek.com for additional troubleshooting suggestions.

Appendix B

Bulk Preparation of Electrophoresis Buffer and Agarose Gels

To save time, the electrophoresis buffer and agarose gel solution can be prepared in larger quantities for sharing by the class. Unused diluted buffer can be used at a later time and solidified agarose gel solution can be remelted.

Bulk Electrophoresis Buffer

Quantity (bulk) preparation for 3 liters of 1x electrophoresis buffer is outlined in Table D.

Table D Bulk Preparation of Electrophoresis Buffer			
50x Conc. Buffer	+	Distilled Water	Total Volume Required
60 mL		2,940 mL	3000 mL (3 L)

Batch Agarose Gels (0.8%)

For quantity (batch) preparation of 0.8% agarose gels, see Table E.

1. Use a 500 mL flask to prepare the diluted gel buffer.
2. Pour 3.0 grams of UltraSpec-Agarose™ into the prepared buffer. Swirl to disperse clumps.
3. With a marking pen, indicate the level of solution volume on the outside of the flask.
4. Heat the agarose solution as outlined previously for individual gel preparation. The heating time will require adjustment due to the larger total volume of gel buffer solution.
5. Cool the agarose solution to 60 °C with swirling to promote even dissipation of heat. If evaporation has occurred, add distilled water to bring the solution up to the original volume as marked on the flask in step 3.
6. Dispense the required volume of cooled agarose solution for casting each gel. Measure 30 mL for a 7 x 7 cm tray, 45 mL for a 10 x 7 cm tray, and 60 mL for a 14 x 7 cm tray. **For this experiment, 7 x 7 cm gels are recommended.**
7. Allow the gel to completely solidify. It will become firm and cool to the touch after approximately 20 minutes. Solidified gels can be stored under buffer in the refrigerator for up to 2 weeks. Do not freeze gels.

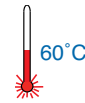

Table E Batch Prep of 0.8% UltraSpec-Agarose™					
Amt of Agarose	+	Concentrated Buffer (50X)	+	Distilled Water	Total Volume
3.0 g		7.5 mL		367.5 mL	375 mL

NOTE:

The UltraSpec-Agarose™ kit component is usually labeled with the amount it contains. Please read the label carefully. If the amount of agarose is not specified or if the bottle's plastic seal has been broken, weigh the agarose to ensure you are using the correct amount.

PROCEED to Loading and Running the Gel (page 14).

Appendix C

Using SYBR® Safe DNA Stain (OPTIONAL)

If desired, the DNA samples in this experiment can be visualized using [SYBR® Safe DNA stain \(Cat #608\)](#).

We recommend adding diluted SYBR® Safe stain to the liquid agarose gels while casting for easy, reproducible results. A blue light or UV transilluminator is needed for visualizing SYBR® gels. The TruBlu™ 2 ([Cat. #557](#)) is highly recommended.

PREPARING SYBR® SAFE STAIN

Instructors:

1. Prepare 1x Electrophoresis Buffer by combining 10 µL of 50X Concentrated Buffer with 490 µL of distilled water.
2. Add 20 µL of the SYBR® Safe to the tube of 1X buffer from Step 1 and mix by tapping the tube several times. The diluted SYBR® Safe Stain is now ready to be used during agarose gel preparation.

AGAROSE GEL PREPARATION

This experiment requires one 0.8% agarose gel for each student group. Instructors can choose whether to prepare the gels in advance (METHOD A) or have the students prepare their own (METHOD B). Allow approximately 30-40 minutes for this procedure.

Instructor Preparation (METHOD A):

For quantity (batch) preparation of agarose gels, see Table E.

1. Use a 500 mL flask to prepare the diluted gel buffer.
2. Pour 3.0 grams of UltraSpec-Agarose™ into the prepared buffer. Swirl to disperse clumps.
3. With a marking pen, indicate the level of solution volume on the outside of the flask.
4. Heat the agarose solution as outlined previously for individual gel preparation. The heating time will require adjustment due to the larger total volume of gel buffer solution.
5. Cool the agarose solution to 60 °C with swirling to promote even dissipation of heat. If evaporation has occurred, add distilled water to bring the solution up to the original volume as marked on the flask in step 3.
6. Add the entire tube of **diluted SYBR® Safe** stain to the cooled agarose and mix well.
7. Dispense the required volume of cooled agarose solution for casting each gel. Measure 30 mL for a 7 x 7 cm tray, 45 mL for a 10 x 7 cm tray, and 60 mL for a 14 x 7 cm tray. **For this experiment, 7 x 7 cm gels are recommended.**
8. Allow the gel to completely solidify. It will become firm and cool to the touch after approximately 20 minutes. Solidified gels can be stored in the refrigerator for up to 2 weeks. Place 1-2 mL of electrophoresis buffer in a sealable bag with the gels to prevent them from drying out. Excessive buffer will cause SYBR® Safe to diffuse out of the gels. Do not freeze gels.

Table E					
Batch Prep of 0.8% UltraSpec-Agarose™					
Amt of Agarose	+	Concentrated Buffer (50X)	+	Distilled Water	Total Volume
3.0 g		7.5 mL		367.5 mL	375 mL

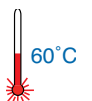

PROCEED to Loading and Running the Gel (Steps 8-12 on page 14), followed by the VISUALIZATION procedures on page 31.

NO ADDITIONAL STAINING IS NECESSARY.

Appendix C

Using SYBR® Safe DNA Stain (OPTIONAL)

AGAROSE GEL PREPARATION, CONTINUED

Student Preparation (METHOD B):

For student preparation of agarose gels, see Table A.2.

1. **DILUTE** concentrated (50X) buffer with distilled water to create 1X buffer (see Table A.2).
2. **MIX** agarose powder with 1X buffer in a 250 mL flask (see Table A).
3. **DISSOLVE** agarose powder by boiling the solution. **MICROWAVE** the solution on high for 1 minute. Carefully **REMOVE** the flask from the microwave and **MIX** by swirling the flask. Continue to **HEAT** the solution in 15-second bursts until the agarose is completely dissolved (the solution should be clear like water).
4. **COOL** agarose to 60 °C with careful swirling to promote even dissipation of heat. 
5. While agarose is cooling, **SEAL** the ends of the gel-casting tray with the rubber end caps. **PLACE** the well template (comb) in the appropriate notch.
6. Before casting the gel, **ADD diluted SYBR® Safe** to the cooled agarose and swirl to mix (see Table A.2).
7. **POUR** the cooled agarose solution into the prepared gel-casting tray. The gel should thoroughly solidify within 20 minutes. The gel will stiffen and become less transparent as it solidifies.
8. **REMOVE** end caps and comb. Take particular care when removing the comb to prevent damage to the wells.

Size of Gel Casting tray	Concentrated Buffer (50x)	Distilled Water	Amt of Agarose	= TOTAL Volume	Diluted SYBR® (Step 6)
7 x 7 cm	0.6 mL	29.4 mL	0.24 g	30 mL	30 µL
10 x 7 cm*	0.9 mL	44.1 mL	0.36 g	45 mL	45 µL
14 x 7 cm	1.2 mL	58.8 mL	0.48 g	60 mL	60 µL

* Recommended gel volume for the EDGE™ Integrated Electrophoresis System.

PROCEED to Loading and Running the Gel (Steps 8-12 on page 14), followed by the VISUALIZATION procedures on page 31. **No additional staining is necessary.**

Appendix C

Using SYBR® Safe DNA Stain (OPTIONAL)

VISUALIZING THE SYBR® GEL

A blue light or UV transilluminator is needed for visualizing SYBR® gels. The TruBlu™ 2 ([Cat. #557](#)) is highly recommended.

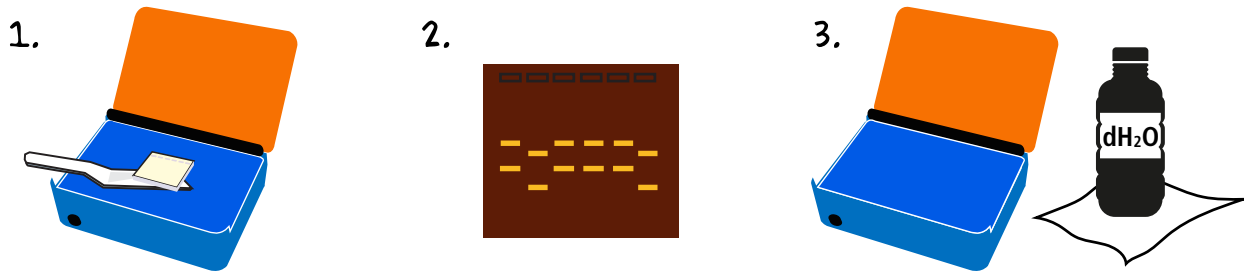

1. **SLIDE** gel off the casting tray onto the viewing surface of the transilluminator.
2. Turn the unit **ON**. DNA should appear as bright green bands on a dark background. **PHOTOGRAPH** results.
3. Turn the unit **OFF**. **REMOVE** and **DISPOSE** of the gel. **CLEAN** the transilluminator surfaces with distilled water.

