

EDVOTEK® • The Biotechnology Education Company®

RECENTLY
UPDATED!

Edvo-Kit #

116

Edvo-Kit #116

Sickle Cell Gene Detection (DNA-Based)

Experiment Objective:

In this experiment, students will gain an understanding of the effect of mutations in health and disease, specifically as it relates to sickle cell disease.

See page 3 for storage instructions.

Version 116.210628

EDVOTEK®

1.800.EDVOTEK • www.edvotek.com • info@edvotek.com

Table of Contents

	Page
Experiment Components	3
Experiment Requirements	3
Background Information	4
Experiment Procedures	
Experiment Overview	7
Module I: Agarose Gel Electrophoresis	9
Module II: Staining Agarose Gels Using FlashBlue™	11
Study Questions	12
Instructor's Guidelines	13
Pre-Lab Preparations	14
Experiment Results and Analysis	16
Study Questions and Answers	17
Appendices	18
A EDVOTEK® Troubleshooting Guide	19
B Bulk Preparation of Electrophoresis Buffer and Agarose Gels	20
C Using SYBR® Safe Stain (OPTIONAL)	21

Safety Data Sheets can be found on our website: www.edvotek.com/safety-data-sheets

Technical Support

1.800.EDVOTEK

Mon. - Fri. 8 AM to 5:30 PM EST



Please Have the Following Info:

- Product Number & Description
- Lot Number on Box
- Order/Purchase Order #

1.800.EDVOTEK • info@edvotek.com • www.edvotek.com

www.edvotek.com

- Online Catalog
- Order Products
- Experiment Protocols
- Tech Support
- Resources!



EDVOTEK and The Biotechnology Education Company are registered trademarks of EDVOTEK, Inc. Ready-to-Load, QuickStrip, FlashBlue, and UltraSpec-Agarose are trademarks of EDVOTEK, Inc. SYBR is a registered trademark of Thermo Fisher Scientific.



1.800.EDVOTEK • Fax 202.370.1501 • info@edvotek.com • www.edvotek.com

Duplication of any part of this document is permitted for non-profit educational purposes only. Copyright © 1989-2022 EDVOTEK, Inc., all rights reserved. Version 116.210628

Experiment Components

READY-TO-LOAD™ SAMPLES FOR ELECTROPHORESIS

Components (in QuickStrip™ format)

Store QuickStrip™ samples in the refrigerator upon receipt.

	Check (✓)
A Sickle cell gene sample	<input type="checkbox"/>
B Sickle cell trait (carrier) sample	<input type="checkbox"/>
C Normal gene sample	<input type="checkbox"/>
D Mother's DNA sample	<input type="checkbox"/>
E Child's DNA sample	<input type="checkbox"/>
F Father's DNA sample	<input type="checkbox"/>

Experiment #116 is designed for 8 groups.

Store QuickStrip™ samples in the refrigerator immediately upon receipt. All other components can be stored at room temperature.

REAGENTS & SUPPLIES

Store the following at room temperature.

• UltraSpec-Agarose™	<input type="checkbox"/>
• Electrophoresis Buffer (50x)	<input type="checkbox"/>
• Practice Gel Loading Solution	<input type="checkbox"/>
• FlashBlue™ DNA Stain	<input type="checkbox"/>

Requirements

- Horizontal gel electrophoresis apparatus
- D.C. power supply
- Automatic micropipettes with tips
- Balance
- Microwave, hot plate or burner
- Pipet pump
- 250 mL flasks or beakers
- Hot gloves
- Safety goggles and disposable laboratory gloves
- Small plastic trays or large weigh boats (for gel destaining)
- DNA visualization system (white light)
- Distilled or deionized water

All experiment components are intended for educational research only. They are not to be used for diagnostic or drug purposes, nor administered to or consumed by humans or animals.

Background Information

SICKLE CELL DISEASE

Sickle cell disease (SCD) is an inherited blood disorder that affects around 5 million people worldwide. The disease is caused by small changes in an individual's genetic coding that interfere with their body's ability to create hemoglobin – a protein that transports oxygen. Changes to hemoglobin primarily affect red blood cells. Individuals with SCD have red blood cells that are misshaped, stiff, sticky and short-lived (Figure 1). As a result, these individuals often have anemia – a medical condition characterized by low red blood cell numbers and low blood oxygen levels. Many people with SCD also experience periodic blood clots, that block the flow of oxygen to other important organs, and have compromised spleens. These conditions result in a number of symptoms ranging from chronic tiredness to heart attacks.

Symptoms of sickle cell disease usually appear 5-6 months after birth. In children, the disorder can cause delayed growth and development, yellowing of the skin and eyes, secondary infections like pneumonia, and episodes of pain called “pain crisis”. If untreated these symptoms worsen with time. Adults with severe SCD can experience chronic pain, fatigue, aseptic necrosis (localized bone death), vision loss, as well as life-threatening lung and heart injuries. In less severe cases, the main symptoms are tiredness, dizziness, difficulty breathing, and a weakened immune system.

Medical researchers are currently working to find a cure for this disease. One option is a bone marrow transplant. However, this requires a closely matched marrow donor, several rounds of chemotherapy, and years of taking immunosuppressive drugs. Consequently, transplants are saved for severe cases of SCD in otherwise healthy and young patients. Another potential cure is gene therapy - using biotechnologies like CRISPR to introduce a healthy copy of the mutated hemoglobin gene into a patient's genome (see Box 1). Such strategies are promising but still being carefully tested. In the meantime, proper medical care and lifestyle changes can help an individual with SCD avoid pain crisis, lessen other symptoms, and prevent complications.

Early and accurate identification of SCD is essential to treating the disease but can be challenging. This is because affected individuals show a wide range of symptoms and because these symptoms are not distinct to the disease. Luckily, many places in the US now automatically screen newborns for sickle cell disease. This is sometimes done by measuring the level of hemoglobin in a blood sample or by observing red blood cells under a microscope. However, early in a baby's life, the production of a different type of hemoglobin called fetal hemoglobin may mask these physical traits of the disease. A more accurate test is to look at the individual's DNA for the root source of the disorder.

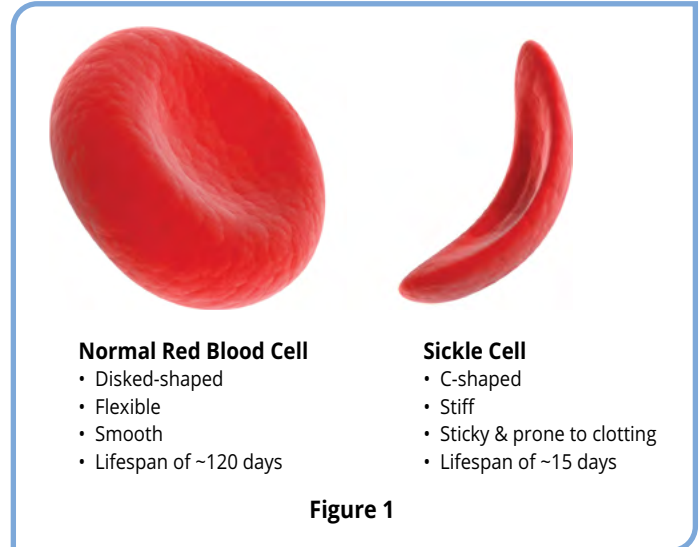

Box 1:

In the summer of 2019, Victoria Gray underwent an experimental treatment where researchers collected bone marrow cells, edited their genetic material to produce fetal hemoglobin, destroyed most of her unedited bone marrow cells, and then reintroduced the edited cells. The initial results were promising – Ms. Gray observed a dramatic reduction in most SCD symptoms and her blood tests showed healthy hemoglobin and red blood cell levels. However, scientists are still carefully monitoring the long term effects of the treatment. Because Victoria Gray was the first U.S. patient to be treated using CRISPR, her story was widely published.

AN INHERITED DISORDER

Researchers have identified around 400 different DNA changes that can lead to SCD. The most common is an A to T single nucleotide mutation that alters the amino acid sequence of a protein known as beta-globin. More specifically, this DNA coding change causes cells to build beta-globin proteins that contain the amino acid valine instead of glutamic acid (Figure 2). Because these two amino acids have different charges this alters key properties a person's beta-globin and, in turn, their hemoglobin (Figure 3). Other subtypes of the disease are caused by similar nucleotide changes in the same gene.

The beta-globin gene is found on chromosome 11 and contains the body's only set of instructions for making an essential part of most hemoglobin proteins. Because it is located on an autosomal (or paired) chromosome each individual has two copies – one that they inherited from their mother and one that they inherited from their father. However, humans need only one "normal" beta-globin gene to produce a sufficient supply of healthy hemoglobin. In such a case, the normal gene is called "dominant" because its effects can compensate for a mutated gene. Similarly, SCD is called a "recessive" disease because symptoms only appear when someone has two mutant versions of the beta-globin gene.

A recessive disease like SCD can be difficult to trace through a family tree because the disease can "skip" multiple generations. This happens whenever there is a generation of carriers – heterozygous individuals with a dominant normal gene that masks the continued presence of the disease-causing mutation. At the same time, this disease is caused by a single gene located on an autosomal chromosome which makes its inheritance pattern easier to predict.

Inheritance of a single gene can be illustrated with a two-by-two grid known as a Punnett Square (Figure 4). Punnett Squares diagram alleles - alternative forms of a gene that are created by mutations. The alleles carried by one parent are placed across the top of the grid (columns), and the alleles contributed by the other parent are placed down the side of the grid (rows). By convention, the dominant allele is denoted by an upper-case letter and the recessive allele by a lower-case letter. Next, the parental alleles are used to fill in the grid. Each box in the grid is assigned the allele at the head of its column and row.

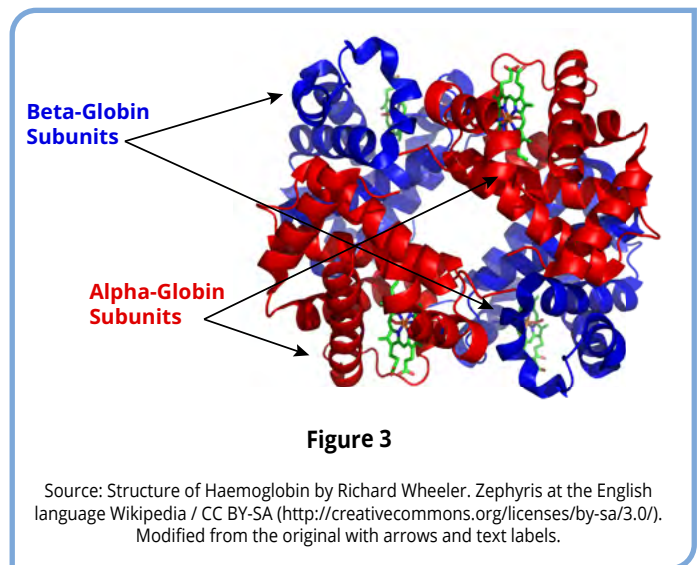
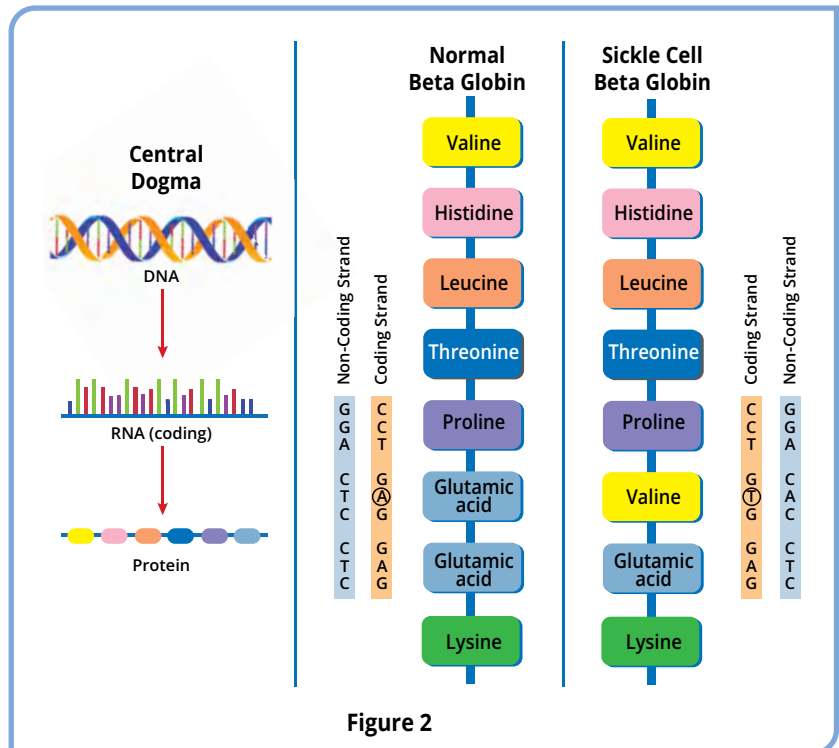

	T	t	Genotype
T	TT	Tt	1/4 TT 1/2 Tt 1/4 tt
t	Tt	tt	Phenotype 3/4 dominant 1/4 recessive

Figure 4

Genetic counselors use Punnett squares to predict the probability that two healthy adults will have a child with sickle cell disease. For example, in the situation depicted in Figure 4, both potential parents are heterozygous. These individuals will have few or no symptoms of the disease and may not even know they have the mutation. However, they have a 25% chance of having a child with the disease – the homozygous recessive genotype. They also have a 25% chance of having a healthy child with two normal genes – the homozygous dominant genotype. Finally, they have a 50% chance of having a heterozygous child like themselves.

How can couples who are considering children determine whether their beta-globin genotype is homozygous dominant or heterozygous? How can young babies be screened for this disease when early blood tests may be inconclusive? By using biotechnologies that allow users to read – or at least deduce - the exact sequence of As, Ts, Gs, and Cs that make up an individual's genome.

DETECTING SICKLE CELL DISEASE USING BIOTECHNOLOGY

Parental or fetal DNA from cells obtained from amniocentesis can now be analyzed with a high degree of accuracy. DNA from a few cells can provide sufficient DNA to be amplified using Polymerase Chain Reaction (PCR). Alternatively, cells can be grown in a culture to yield a large amount of genomic DNA. Once DNA has been collected from a patient, clinicians use various biotechnologies in order to visualize specific nucleotides that make up that individual's genotype.

One way to identify small differences in the nucleotide DNA sequences of different individuals is to use restriction enzymes. Restriction enzymes are endonucleases which catalyze the cleavage of phosphodiester bonds within both DNA strands. This process, called digestion, results in DNA molecules that are cut at very specific sites. These cut sites occur in or near palindromic sequences of bases called recognition sites, which are generally 4 to 8 base pairs in length. Because many restriction enzyme recognition sites are also polymorphic, a restriction enzyme digestion results in a unique mixture of differently sized DNA fragments for each individual tested. These variations, called Restriction Fragment Length Polymorphism (RFLP), allow us to identify inherited diseases like SCD.

The basis of the test in this experiment is the recognition by restriction enzymes of a palindromic sequence in the beta-globin gene. In the normal beta-globin gene, the sequence of nucleotides that specifies amino acids 5, 6 and 7 (Pro-Glu-Glu) are CCT- GAG-GAG (Figure 2). A point mutation in codon 6 converts the A to T and changes the sequence to CCT-GTG-GAG. The palindromic recognition site of the restriction enzyme *Mst* II is CCTNAGG, where N can be any of the four nucleotides. Close examination of the sequence shows that *Mst* II will recognize the normal beta-globin CCT-GAG-G where N is a G, but not the mutated form. Therefore, when a patient's sample is mixed with *Mst* II the enzyme will cut the normal gene into two separate fragments but not the mutated gene.

These fragments can be visualized and sized using gel electrophoresis. In gel electrophoresis the amplified product is added into depressions (or "wells") within a gel, and then an electrical current is passed through the gel. Because the sugar-phosphate backbone of DNA has a strong negative charge, the current drives the DNA through the gel towards the positive electrode. On the molecular level, the gel contains small channels through which the DNA can pass. Small DNA fragments move through these holes easily, but large DNA fragments have a more difficult time squeezing through the tunnels. Because molecules with dissimilar sizes travel at different speeds, they become separated and form discrete "bands" within the gel. After the current is stopped, the bands can be visualized using a stain that sticks to DNA. The DNA fragment length is then calculated by comparing the distance the band traveled to a DNA ladder made up of several known lengths.

Experiment Overview

EXPERIMENT OBJECTIVE

In this experiment, students will gain an understanding of the effect of mutations in health and disease, specifically as it relates to sickle cell disease.

LABORATORY SAFETY

1. Gloves and goggles should be worn routinely as good laboratory practice.
2. Exercise extreme caution when working with equipment that is used in conjunction with the heating and/or melting of reagents.
3. DO NOT MOUTH PIPET REAGENTS - USE PIPET PUMPS.
4. Exercise caution when using any electrical equipment in the laboratory.
5. Always wash hands thoroughly with soap and water after handling reagents or biological materials in the laboratory.



LABORATORY NOTEBOOKS

Scientists document everything that happens during an experiment, including experimental conditions, thoughts and observations while conducting the experiment, and, of course, any data collected. Today, you'll be documenting your experiment in a laboratory notebook or on a separate worksheet.

Before starting the Experiment:

- Carefully read the introduction and the protocol. Use this information to form a hypothesis for this experiment.
- Predict the results of your experiment.

During the Experiment:

- Record your observations.

After the Experiment:

- Interpret the results – does your data support or contradict your hypothesis?
- If you repeated this experiment, what would you change? Revise your hypothesis to reflect this change.

Experiment Overview

MODULE I: Agarose Gel Electrophoresis

Time required: See Table C

Quick Reference for EDVO-Kit #116			
Size of gel casting tray	Groups per gel	Placement of comb	Wells required per group
7 x 7 cm	1 group	1st set of notches	6
10 x 7 cm	1 group	1st set of notches	6
14 x 7 cm	2 groups	1st and 3rd sets of notches	6

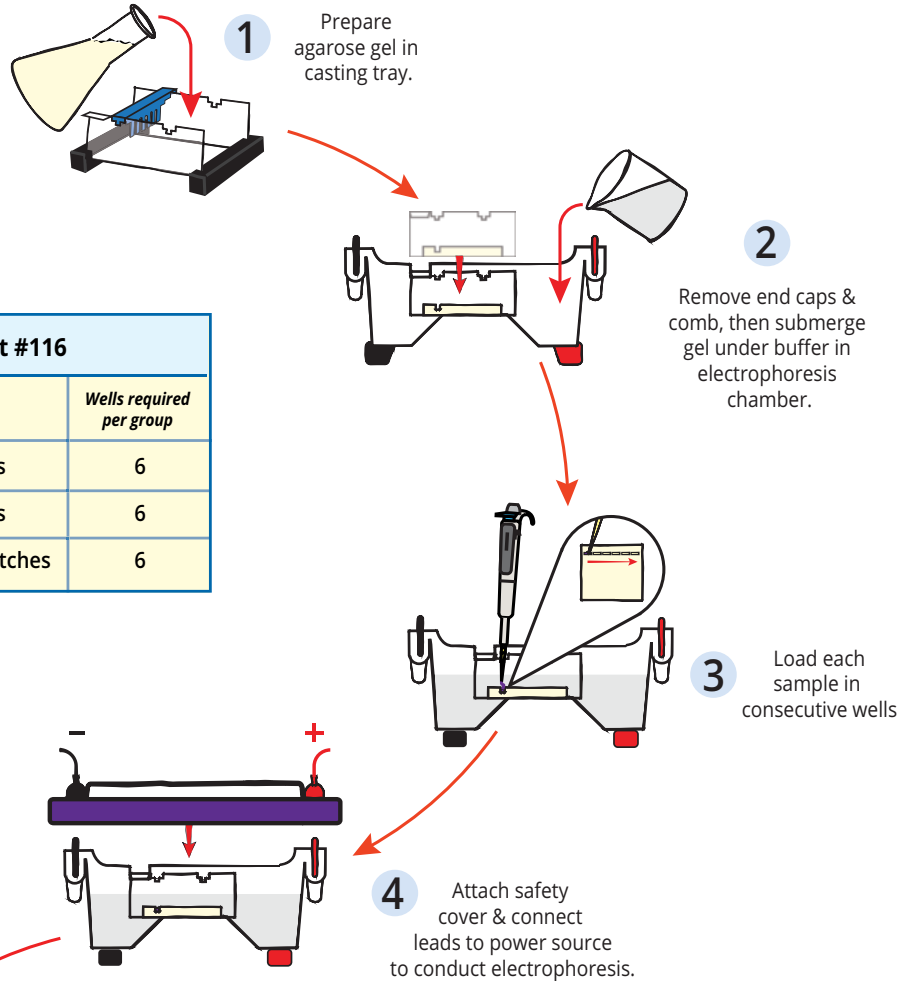

MODULE II: Staining Agarose Gels Using FlashBlue™

Time required: 30 min.

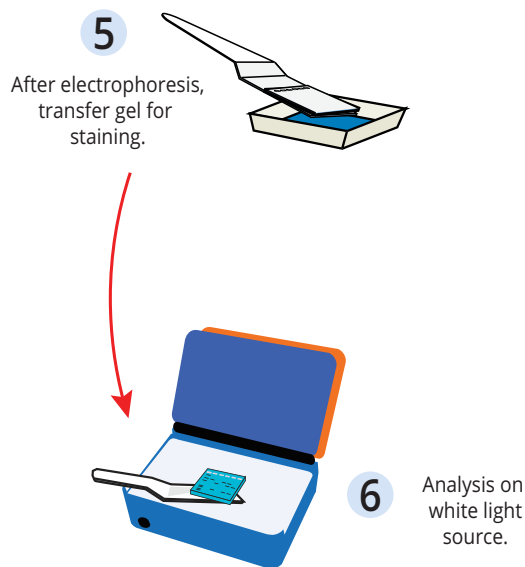

Related EDVOTEK® Instructional Videos

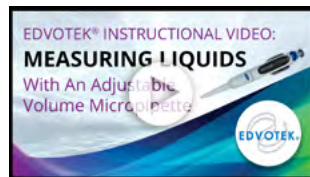

www.youtube.com/edvotekinc

Module I: Agarose Gel Electrophoresis

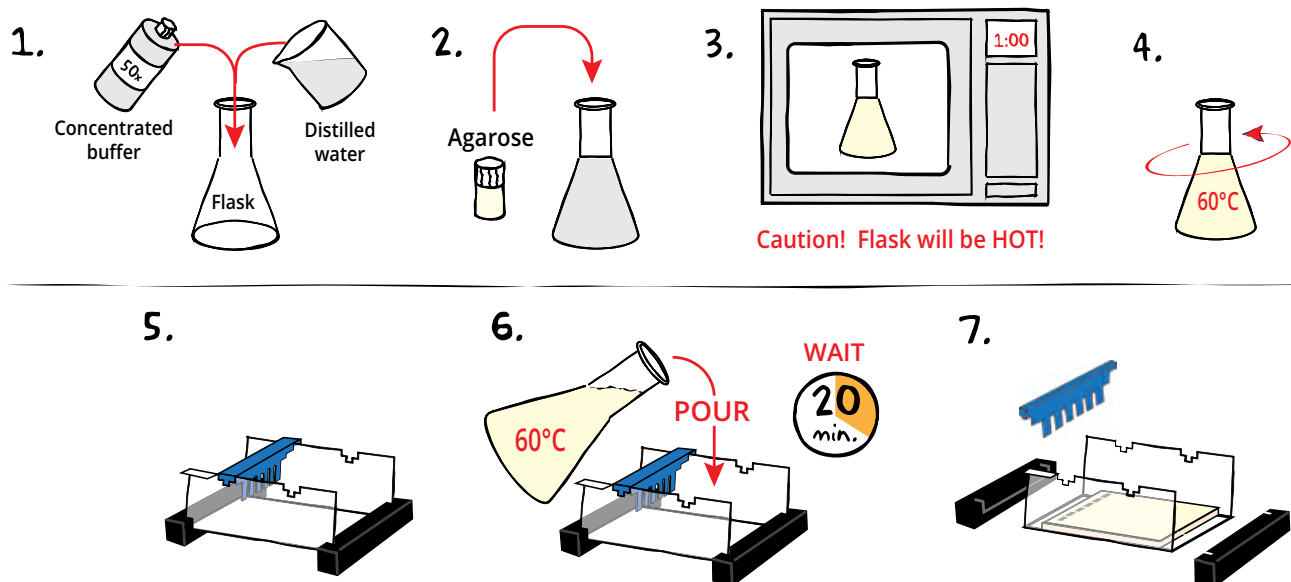

CASTING THE AGAROSE GEL

- DILUTE** concentrated 50X Electrophoresis buffer with distilled water (refer to Table A for correct volumes depending on the size of your gel casting tray).
- MIX** agarose powder with buffer solution in a 250 mL flask (refer to Table A).
- DISSOLVE** agarose powder by boiling the solution. **MICROWAVE** the solution on high for 1 minute. Carefully **REMOVE** the flask from the microwave and **MIX** by swirling the flask. Continue to **HEAT** the solution in 15-second bursts until the agarose is completely dissolved (the solution should be clear like water).
- COOL** agarose to 60 °C with careful swirling to promote even dissipation of heat.
- While agarose is cooling, **SEAL** the ends of the gel-casting tray with the rubber end caps. **PLACE** the well template (comb) in the appropriate notch.
- POUR** the cooled agarose solution into the prepared gel-casting tray. The gel should thoroughly solidify within 20 minutes. The gel will stiffen and become less transparent as it solidifies.
- REMOVE** end caps and comb. Take particular care when removing the comb to prevent damage to the wells.



REMINDER:
This experiment requires 0.8% agarose gels cast with 6 wells.

Table A Individual 0.8% UltraSpec-Agarose™ Gels				
Size of Gel Casting tray	Concentrated Buffer (50x)	+ Distilled Water	+ Amt of Agarose	= TOTAL Volume
7 x 7 cm	0.6 mL	29.4 mL	0.24 g	30 mL
10 x 7 cm*	0.9 mL	44.1 mL	0.36 g	45 mL
14 x 7 cm	1.2 mL	58.8 mL	0.48 g	60 mL

*Recommended gel volume for the EDGE™ Integrated Electrophoresis System. (Cat. #500).

Module I: Agarose Gel Electrophoresis

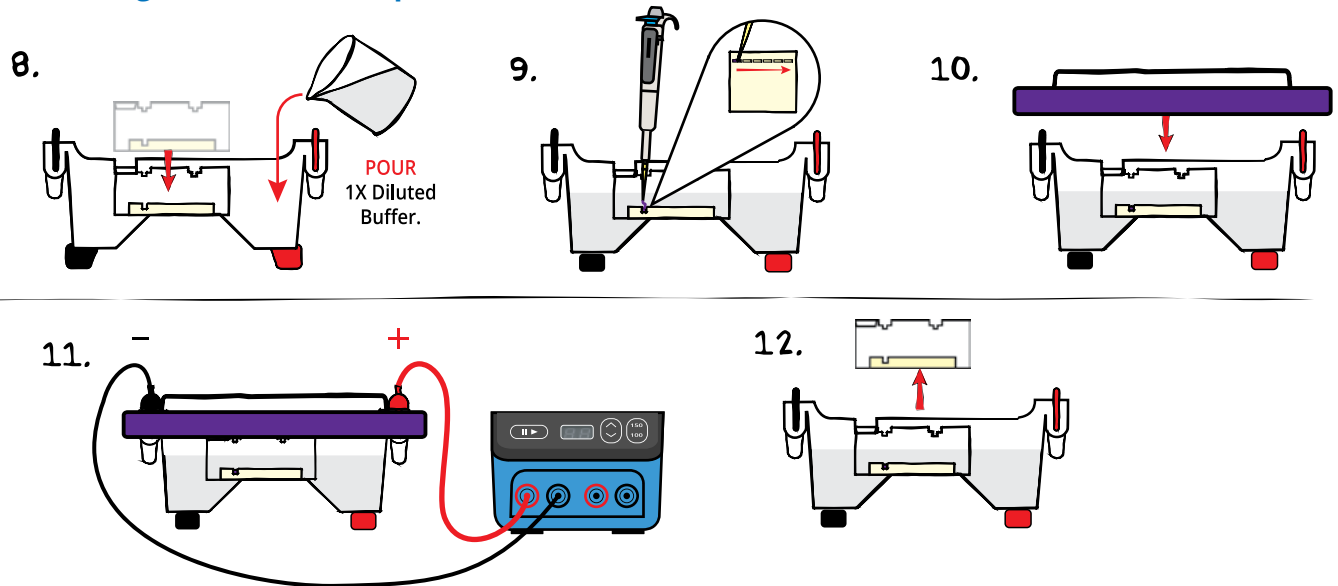

RUNNING THE GEL

8. **PLACE** the gel (still on the tray*) into the electrophoresis chamber. **COVER** the gel with 1X Electrophoresis Buffer (See Table B for recommended volumes). The gel should be completely submerged.
9. **PUNCTURE** the foil overlay of the QuickStrip™ with a pipet tip. **LOAD** the entire sample (35 µL) into the well in the order indicated by Table 1, at right.
10. **PLACE** safety cover on the unit. **CHECK** that the gel is properly oriented. Remember, the DNA samples will migrate toward the positive (red) electrode.
11. **CONNECT** leads to the power source and **PERFORM** electrophoresis (See Table C for time and voltage guidelines). Allow the tracking dye to migrate at least 3 cm from the wells.
12. After electrophoresis is complete, **REMOVE** the gel and casting tray from the electrophoresis chamber.

REMINDER:
Before loading the samples, make sure the gel is properly oriented in the apparatus chamber.

TABLE 1: GEL LOADING

Lane	Tube	Sample
1	Tube A	Sickle cell gene sample
2	Tube B	Sickle cell trait (carrier) sample
3	Tube C	Normal gene sample
4	Tube D	Mother's DNA sample
5	Tube E	Child's DNA sample
6	Tube F	Father's DNA sample

Table B
1x Electrophoresis Buffer (Chamber Buffer)

EDVOTEK Model #	Total Volume Required	Dilution	
		50x Conc. Buffer	+ Distilled Water
EDGE™	150 mL	3 mL	147 mL
M12	400 mL	8 mL	392 mL
M36	1000 mL	20 mL	980 mL

Table C
Time and Voltage Guidelines (0.8% Agarose Gel)

Volts	Electrophoresis Model	
	EDGE™	M12 & M36
	Min/Max (minutes)	Min/Max (minutes)
150	10/20	20/35
125	N/A	30/45
100	15/25	40/60

*Gels that have previously been removed from their trays should be "anchored" back to the tray with a few drops of molten agarose before placing into the electrophoresis chamber. This will prevent the gels from sliding around in the trays and the chambers.

Module II: Staining Agarose Gels Using FlashBlue™

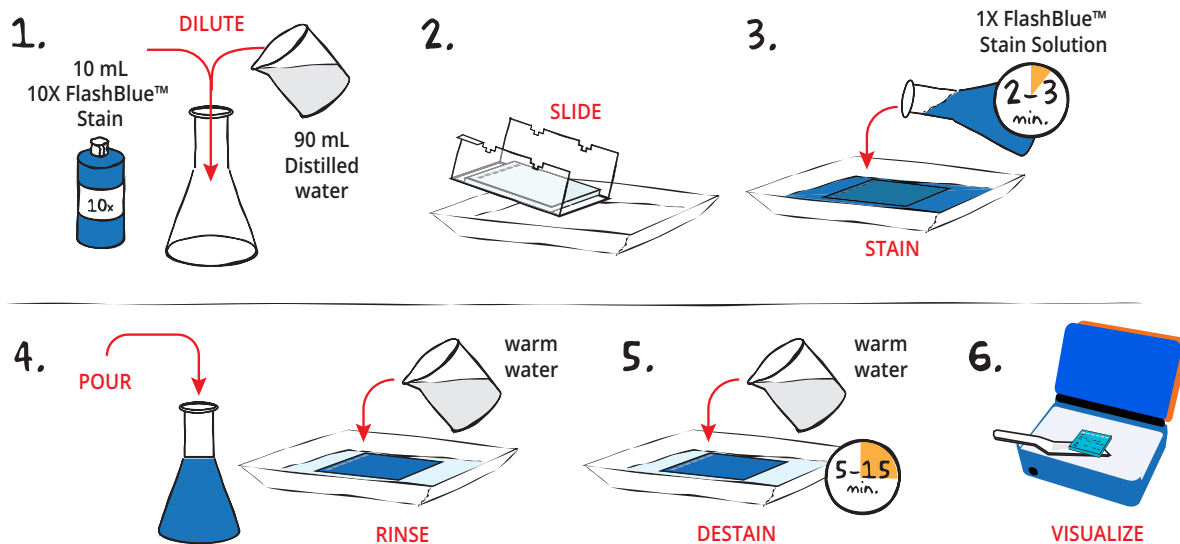

- DILUTE** 10 mL of 10X concentrated FlashBlue™ with 90 mL of distilled water in a flask. **MIX** well.
- REMOVE** the agarose gel and casting tray from the electrophoresis chamber. **SLIDE** the gel off the casting tray into a small, clean gel-staining tray.
- COVER** the gel with the 1X FlashBlue™ stain solution. **STAIN** the gel for 2-3 minutes. For best results, use an orbital shaker to gently agitate the gel while staining. **STAINING THE GEL FOR LONGER THAN 3 MINUTES WILL REQUIRE EXTRA DESTAINING TIME.**
- POUR** the 1X FlashBlue™ back into the flask (the stain can be reused). **COVER** the gel with warm water (40-45 °C). Gently **RINSE** the gel for 20-30 seconds. **POUR** off the water.
- COVER** the gel with clean, warm water (40-45 °C). **DESTAIN** for 5-15 minutes with gentle shaking (longer periods will yield better results). DNA bands will start to appear after 5 minutes of destaining. Changing the water frequently will accelerate destaining.
- Carefully **REMOVE** the gel from the destaining liquid. **VISUALIZE** results using a white light visualization system. DNA will appear as dark blue bands on a light blue background.



ALTERNATIVE FLASHBLUE™ STAINING PROTOCOL:

- DILUTE** 1 mL of 10X FlashBlue™ stain with 149 mL distilled water.
- COVER** the gel with diluted FlashBlue™ stain.
- SOAK** the gel in the staining liquid for at least three hours. For best results, stain gels overnight.
- Carefully **REMOVE** the gel from the staining liquid. **VISUALIZE** results using a white light visualization system. DNA will appear as dark blue bands on a light blue background.

Study Questions

Answer the following study questions in your laboratory notebook or on a separate worksheet.

1. Create a Punnett Square for a couple where one parent has two normal beta-globin genes and one parent has sickle cell disease. What are the chances that this couple will have a child with the disease? What are the chances that they will have a child who is a carrier?
2. What are restriction enzymes and how can they be used to visualize polymorphic regions in an individual's DNA?
3. Brainstorm reasons why early detection is such an important part of treating sickle cell disease.

Instructor's Guide

ADVANCE PREPARATION:

PREPARATION FOR:	WHAT TO DO:	WHEN?	TIME REQUIRED:
Module I: Agarose Gel Electrophoresis	Prepare QuickStrips™.	Up to one day before performing the experiment.	45 min.
	Prepare diluted electrophoresis buffer.		
	Prepare molten agarose and pour gels.		
Module II: Staining Agarose Gels Using FlashBlue™	Prepare staining components.	The class period or overnight after the class period.	10 min.

Technical Support

1.800.EDVOTEK

Mon. - Fri. 8 AM to 5:30 PM EST



Please Have the Following Info:

- Product Number & Description
- Lot Number on Box
- Order/Purchase Order #

1.800.EDVOTEK • info@edvotek.com • www.edvotek.com

www.edvotek.com

- Online Catalog
- Order Products
- Experiment Protocols
- Tech Support
- Resources!



Pre-Lab Preparations: Module I

AGAROSE GEL ELECTROPHORESIS

This experiment requires 0.8% agarose gels. Enough reagents are provided to cast either eight 7 x 7 cm gels, eight 10 x 7 cm gels, or four 14 x 7 cm gels. You can choose whether to prepare the gels in advance or have students prepare their own. Allow approximately 30 minutes for this procedure.

Quick Reference for EDVO-Kit #116			
Size of gel casting tray	Groups per gel	Placement of comb	Wells required per group
7 x 7 cm	1 group	1st set of notches	6
10 x 7 cm	1 group	1st set of notches	6
14 x 7 cm	2 groups	1st and 3rd sets of notches	6

Individual Gel Preparation:

Each student group can be responsible for casting their own individual gel prior to conducting the experiment. See Module I in the Student's Experimental Procedure. Students will need 50x concentrated buffer, distilled water and agarose powder.

Batch Gel Preparation:

To save time, a larger quantity of agarose solution can be prepared for sharing by the class. Electrophoresis buffer can also be prepared in bulk. See Appendix B.

Preparing Gels in Advance:

Gels may be prepared ahead and stored for later use. Solidified gels can be stored under buffer in the refrigerator for up to 2 weeks.

Do not freeze gels at -20 °C as freezing will destroy the gels.

Gels that have been removed from their trays for storage should be "anchored" back to the tray with a few drops of molten agarose before being placed into the tray. This will prevent the gels from sliding around in the trays and the chambers.

SAMPLES FORMAT: PREPARING THE QUICKSTRIPS™

QuickStrip™ tubes consist of a microtiter block covered with a protective foil overlay. Each well contains pre-aliquoted sample.

Using sharp scissors, carefully divide the block of tubes into individual strips by cutting between the rows (see diagram at right). Take care not to damage the foil overlay while separating the samples.

Each lab group will receive one set of tubes. Before loading the gel, remind students to tap the tubes to collect the sample at the bottom of the tube. Puncture the foil overlay of the QuickStrip™ with a pipet tip to aspirate the sample. **Do not remove the foil as samples can spill.**

FOR MODULE I Each group will need:

- 50x concentrated buffer
- Distilled Water
- UltraSpec-Agarose™
- QuickStrip™ Samples

NOTE:

This kit is compatible with **SYBR® Safe Stain** (Cat #608, not included). Instructions for preparing gels and visualizing results can be found in Appendix C.

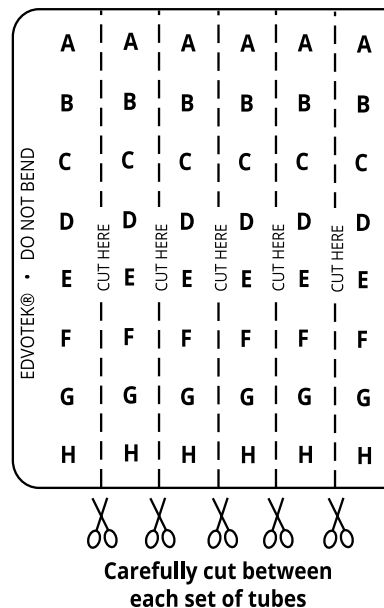

Pre-Lab Preparations: Module II

STAINING AGAROSE GELS USING FLASHBLUE™

FlashBlue™ stain is optimized to shorten the time required for both staining and destaining steps. Agarose gels can be stained with diluted FlashBlue™ for 5 minutes and destained for only 20 minutes. For the best results, leave the gel in liquid overnight. This will allow the stained gel to “equilibrate” in the destaining solution, resulting in dark blue DNA bands contrasting against a uniformly light blue background. A white light box ([Cat. #552](#)) is recommended for visualizing gels stained with FlashBlue™.

- Stained gels may be stored in destaining liquid for several weeks with refrigeration, although the bands may fade with time. If this happens, re-stain the gel.
- Destained gels can be discarded in solid waste disposal. Destaining solutions can be disposed of down the drain.

FOR MODULE II Each group will need:

- 10 mL 10X concentrated FlashBlue *OR* 100 mL 1x diluted FlashBlue
- Small plastic tray or weight boat
- Distilled or deionized water

PHOTODOCUMENTATION OF DNA (OPTIONAL)

Once gels are stained, you may wish to photograph your results. There are many different photodocumentation systems available, including digital systems that are interfaced directly with computers. Specific instructions will vary depending upon the type of photodocumentation system you are using.

NOTE:

Accurate pipetting is critical for maximizing successful experiment results. EDVOTEK Series 100 experiments are designed for students who have had previous experience with micropipetting techniques and agarose gel electrophoresis.

If students are unfamiliar with using micropipettes, we recommended performing [Cat. #S-44, Micropipetting Basics](#) or [Cat. #S-43, DNA DuraGel™](#) prior to conducting this experiment.

Experiment Results and Analysis

GEL DATA EXPLANATION:

Please read about Sickle cell gene analysis using a specific restriction enzyme in the background section.

Lane 1:

Control sample for Sickle cell patient

No restriction enzyme site is available in either of the two copies of the gene. No restriction enzyme digestion of either gene. The pattern will be one band on electrophoresis.

Lane 2:

Control sample for heterozygous Sickle cell trait

One of the pair of genes (the normal gene) contains the restriction enzyme site. This gene is cut by the restriction to produce two smaller pieces of DNA. The second copy of the gene has a mutation within the palindrome. This change does not allow the enzyme to cut the mutated gene into two smaller pieces. The pattern will yield three DNA bands on electrophoresis.

Lane 3:

Control sample for Normal homozygous patient

Both normal genes contain the restriction enzyme palindrome and both genes are digested to give the two smaller DNA bands.

Lane 4:

Mother DNA sample analysis

The mother is heterozygous for the sickle trait. One of the pair of genes (the normal gene) contains the restriction enzyme site. This gene is cut by the restriction to produce two smaller pieces of DNA. The second gene has a mutation within the palindrome. This change does not allow the enzyme to cut the mutated gene into two smaller pieces. The pattern will yield three DNA bands on electrophoresis.

Lane 5:

Child DNA sample analysis

The child is homozygous for the sickle trait and suffers from sickle cell anemia. Both genes have the mutation in the restriction enzyme palindrome. Neither will be cut by the restriction enzyme and the pattern will be a single DNA band on electrophoresis.

Lane 6:

Father DNA sample analysis

The father is heterozygous for the sickle trait. One of the pair of genes (the normal gene) contains the restriction enzyme site. This gene is cut by the restriction to produce two smaller pieces of DNA. The second gene has a mutation within the palindrome. This change does not allow the enzyme to cut the mutated gene into two smaller pieces. The pattern will yield three DNA bands on electrophoresis.

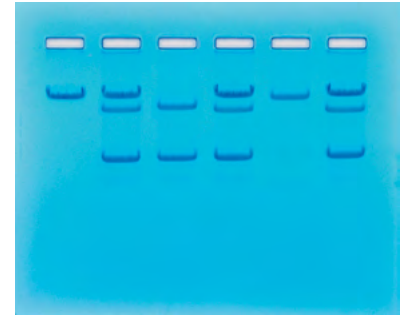

**Please refer to the kit
insert for the Answers to
Study Questions**

Appendices

- A EDVOTEK® Troubleshooting Guide
- B Bulk Preparation of Electrophoresis Buffer and Agarose Gels
- C Using SYBR® Safe Stain (OPTIONAL)

Safety Data Sheets can be found on our website: www.edvotek.com/safety-data-sheets

Technical Support

1.800.EDVOTEK

Mon. - Fri. 8 AM to 5:30 PM EST



Please Have the Following Info:

- Product Number & Description
- Lot Number on Box
- Order/Purchase Order #

1.800.EDVOTEK • info@edvotek.com • www.edvotek.com

www.edvotek.com

- Online Catalog
- Order Products
- Experiment Protocols
- Tech Support
- Resources!



Appendix A

EDVOTEK® Troubleshooting Guides

PROBLEM:	CAUSE:	ANSWER:
Bands are not visible on the gel.	The gel was not prepared properly.	Ensure that the electrophoresis buffer was correctly diluted.
	The gel was not stained properly.	Repeat staining.
	Malfunctioning electrophoresis unit or power source.	Contact the manufacturer of the electrophoresis unit or power source.
After staining the gel, the DNA bands are faint.	The gel was not stained for a sufficient period of time.	Repeat staining protocol.
	The background of gel is too dark.	Destain the gel for 5-10 minutes in distilled water.
DNA bands were not resolved.	Tracking dye should migrate at least 3.5 cm (if using a 7x7 cm tray), and at least 6 cm (if using a 7x14 cm tray) from the wells to ensure adequate separation.	Be sure to run the gel at least 6 cm before staining and visualizing the DNA (approximately one hour at 125 V).
DNA bands fade when gels are kept at 4 °C.	DNA stained with FlashBlue™ may fade with time.	Re-stain the gel with FlashBlue™.
There is no separation between DNA bands, even though the tracking dye ran the appropriate distance.	The wrong percent gel was used for electrophoretic separation.	Be sure to prepare the correct percent agarose gel. For reference, the Ready-to-Load™ DNA samples should be analyzed using a 0.8% agarose gel.
There's not enough sample in my QuickStrip™.	The QuickStrip™ has dried out.	Add 40 µL water, gently pipet up and down to mix before loading.

Visit www.edvotek.com for additional troubleshooting suggestions.

Appendix B

Bulk Preparation of Electrophoresis Buffer and Agarose Gels

To save time, the electrophoresis buffer and agarose gel solution can be prepared in larger quantities for sharing by the class. Unused diluted buffer can be used at a later time and solidified agarose gel solution can be remelted.

Bulk Electrophoresis Buffer

Quantity (bulk) preparation for 3 liters of 1x electrophoresis buffer is outlined in Table D.

Table D Bulk Preparation of Electrophoresis Buffer			
50x Conc. Buffer	+	Distilled Water	Total Volume Required
60 mL		2,940 mL	3000 mL (3 L)

Batch Agarose Gels (0.8%)

For quantity (batch) preparation of 0.8% agarose gels, see Table E.

1. Use a 500 mL flask to prepare the diluted gel buffer.
2. Pour 3.0 grams of UltraSpec-Agarose™ into the prepared buffer. Swirl to disperse clumps.
3. With a marking pen, indicate the level of solution volume on the outside of the flask.
4. Heat the agarose solution as outlined previously for individual gel preparation. The heating time will require adjustment due to the larger total volume of gel buffer solution.
5. Cool the agarose solution to 60 °C with swirling to promote even dissipation of heat. If evaporation has occurred, add distilled water to bring the solution up to the original volume as marked on the flask in step 3.
6. Dispense the required volume of cooled agarose solution for casting each gel. Measure 30 mL for a 7 x 7 cm tray, 45 mL for a 10 x 7 cm tray, and 60 mL for a 14 x 7 cm tray. **For this experiment, 7 x 7 cm gels are recommended.**
7. Allow the gel to completely solidify. It will become firm and cool to the touch after approximately 20 minutes. Solidified gels can be stored under buffer in the refrigerator for up to 2 weeks. Do not freeze gels.

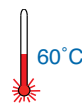

Table E Batch Prep of 0.8% UltraSpec-Agarose™					
Amt of Agarose	+	Concentrated Buffer (50X)	+	Distilled Water	Total Volume
3.0 g		7.5 mL		367.5 mL	375 mL

NOTE:

The UltraSpec-Agarose™ kit component is usually labeled with the amount it contains. Please read the label carefully. If the amount of agarose is not specified or if the bottle's plastic seal has been broken, weigh the agarose to ensure you are using the correct amount.

PROCEED to Loading and Running the Gel (page 10).

Appendix C

Using SYBR® Safe DNA Stain (OPTIONAL)

If desired, the DNA samples in this experiment can be visualized using [SYBR® Safe DNA stain \(Cat #608\)](#).

We recommend adding diluted SYBR® Safe stain to the liquid agarose gels while casting for easy, reproducible results. A blue light or UV transilluminator is needed for visualizing SYBR® gels. The TruBlu™ 2 ([Cat. #557](#)) is highly recommended.

PREPARING SYBR® SAFE STAIN

Instructors:

1. Prepare 1x Electrophoresis Buffer by combining 10 µL of 50X Concentrated Buffer with 490 µL of distilled water.
2. Add 20 µL of the SYBR® Safe to the tube of 1X buffer from Step 1 and mix by tapping the tube several times. The diluted SYBR® Safe Stain is now ready to be used during agarose gel preparation.



AGAROSE GEL PREPARATION

This experiment requires one 0.8% agarose gel for each student group. Instructors can choose whether to prepare the gels in advance (METHOD A) or have the students prepare their own (METHOD B). Allow approximately 30-40 minutes for this procedure.

Instructor Preparation (METHOD A):

For quantity (batch) preparation of agarose gels, see Table E.

1. Use a 500 mL flask to prepare the diluted gel buffer.
2. Pour 3.0 grams of UltraSpec-Agarose™ into the prepared buffer. Swirl to disperse clumps.
3. With a marking pen, indicate the level of solution volume on the outside of the flask.
4. Heat the agarose solution as outlined previously for individual gel preparation. The heating time will require adjustment due to the larger total volume of gel buffer solution.
5. Cool the agarose solution to 60 °C with swirling to promote even dissipation of heat. If evaporation has occurred, add distilled water to bring the solution up to the original volume as marked on the flask in step 3.
6. Add the entire tube of **diluted SYBR® Safe** stain to the cooled agarose and mix well.
7. Dispense the required volume of cooled agarose solution for casting each gel. Measure 30 mL for a 7 x 7 cm tray, 45 mL for a 10 x 7 cm tray, and 60 mL for a 14 x 7 cm tray. **For this experiment, 7 x 7 cm gels are recommended.**
8. Allow the gel to completely solidify. It will become firm and cool to the touch after approximately 20 minutes. Solidified gels can be stored in the refrigerator for up to 2 weeks. Place 1-2 mL of electrophoresis buffer in a sealable bag with the gels to prevent them from drying out. Excessive buffer will cause SYBR® Safe to diffuse out of the gels. Do not freeze gels.

Amt of Agarose	+	Concentrated Buffer (50X)	+	Distilled Water	Total Volume
3.0 g		7.5 mL		367.5 mL	375 mL



PROCEED to Loading and Running the Gel (Steps 8-12 on page 10), followed by the VISUALIZATION procedures on page 23.

NO ADDITIONAL STAINING IS NECESSARY.

Appendix C

Using SYBR® Safe DNA Stain (OPTIONAL)

AGAROSE GEL PREPARATION, CONTINUED

Student Preparation (METHOD B):

For student preparation of agarose gels, see Table A.2.

1. **DILUTE** concentrated (50X) buffer with distilled water to create 1X buffer (see Table A.2).
2. **MIX** agarose powder with 1X buffer in a 250 mL flask (see Table A).
3. **DISSOLVE** agarose powder by boiling the solution. **MICROWAVE** the solution on high for 1 minute. Carefully **REMOVE** the flask from the microwave and **MIX** by swirling the flask. Continue to **HEAT** the solution in 15-second bursts until the agarose is completely dissolved (the solution should be clear like water).

Table A.2 Individual 0.8% UltraSpec-Agarose™ with SYBR® Stain						
Size of Gel Casting tray	Concentrated Buffer (50x)	+ Distilled Water	+ Amt of Agarose	= TOTAL Volume	Diluted SYBR® (Step 6)	
7 x 7 cm	0.6 mL	29.4 mL	0.24 g	30 mL	30 µL	
10 x 7 cm*	0.9 mL	44.1 mL	0.36 g	45 mL	45 µL	
14 x 7 cm	1.2 mL	58.8 mL	0.48 g	60 mL	60 µL	

* Recommended gel volume for the EDGE™ Integrated Electrophoresis System.

4. **COOL** agarose to 60 °C with careful swirling to promote even dissipation of heat. 
5. While agarose is cooling, **SEAL** the ends of the gel-casting tray with the rubber end caps. **PLACE** the well template (comb) in the appropriate notch.
6. Before casting the gel, **ADD diluted SYBR® Safe** to the cooled agarose and swirl to mix (see Table A.2).
7. **POUR** the cooled agarose solution into the prepared gel-casting tray. The gel should thoroughly solidify within 20 minutes. The gel will stiffen and become less transparent as it solidifies.
8. **REMOVE** end caps and comb. Take particular care when removing the comb to prevent damage to the wells.

PROCEED to Loading and Running the Gel (Steps 8-12 on page 10), followed by the VISUALIZATION procedures on page 23. **NO ADDITIONAL STAINING IS NECESSARY.**

Appendix C

Using SYBR® Safe DNA Stain (OPTIONAL)

VISUALIZING THE SYBR® GEL

A blue light or UV transilluminator is needed for visualizing SYBR® gels. The TruBlu™ 2 ([Cat. #557](#)) is highly recommended.

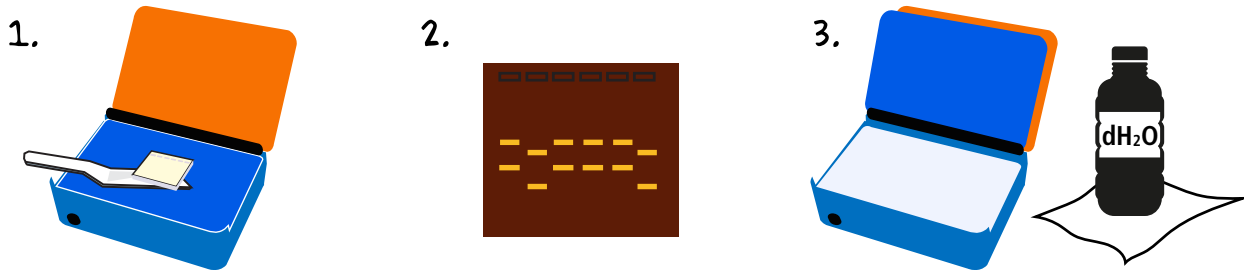

1. **SLIDE** gel off the casting tray onto the viewing surface of the transilluminator.
2. Turn the unit **ON**. DNA should appear as bright green bands on a dark background. **PHOTOGRAPH** results.
3. Turn the unit **OFF**. **REMOVE** and **DISPOSE** of the gel. **CLEAN** the transilluminator surfaces with distilled water.

